

Lighting Control Best Practice Guide

S C H O O L S

LIGHTING CONTROL



Space by space best practices for schools:

- Control needs/solution
- Design considerations
- Floorplan control layout
- Wiring diagram and installation guidelines
- Equipment schedules



LIGHTING CONTROL ABCs

The Watt Stopper has assembled the Lighting Control ABCs program to assist with the design and implementation of lighting controls for educational facilities.

With this program, you can take advantage of The Watt Stopper’s technical expertise, comprehensive product offering, and wide range of best practice guidance, specifically for schools.

Contents

- Introduction to the *Lighting Control Best Practice Guide for Schools* 1
- Value of lighting control for schools 2
- K-12 school space usage 3
- School design guidelines 4
- Influential factors for lighting control 5
- Summary of best practices for lighting control in schools 6-7

- Best Practices
 - Classrooms 9-28
 - Gymnasiums 29-40
 - Hallways 41-44
 - Multipurpose Rooms 45-46
 - Restrooms 47-52
 - Exterior 53-54

- ASHRAE 90.1-2001 Energy Code 56-57

Lighting Control Best Practice Guide for Schools

With nearly 20 years of experience developing and producing lighting controls, The Watt Stopper has helped thousands of organizations identify and implement energy saving lighting control systems. For each facility, there is an optimal lighting control solution, one which meets each owner's need, the occupants' needs, and which can be most effectively operated and maintained. Toward achieving this goal, The Watt Stopper offers comprehensive lighting control products encompassing several product lines: occupancy sensors, lighting control panels, daylighting controls, remote lighting controls, HID controls, and products to promote integrated control among multiple building control systems. With these product resources and unsurpassed technical expertise, The Watt Stopper helps ensure that the right combination of products are used to satisfy the range of control needs for today's schools and their occupants.

This Best Practice publication focuses on design, specification, and installation guidance for lighting control appropriate for K-12 educational facilities. It features applications that illustrate the best control practices for a variety of spaces, facilitating lighting control design and application. With this resource, lighting control design professionals will save time and effort spent on projects. Each best practice meets the provisions of relevant energy codes, reduces lighting operation costs, saves energy, and considers the needs of the primary space occupants – teachers and students.

Each Best Practice includes:

- Description of application
- List of control needs
- Product solution
- Design considerations
- A lighting plan sketch
- Installation notes
- Wiring and installation diagrams
- Equipment schedule



Value of Lighting Control for Schools

Schools spend a significant portion of their annual operating budgets on electricity. According to data compiled by the Energy Information Administration (EIA), electricity expenditures account for 72% of energy costs in educational buildings and of that, more than half is for lighting energy costs. Annual lighting energy usage totals 36 billion kWh. Another study, conducted by American School and University magazine, determined that electricity costs account for half of the total utility costs incurred by educational facilities. And these studies have not taken into account the recent increases in energy costs. So the economic impact of lighting their facilities is one not taken lightly by school administrators.

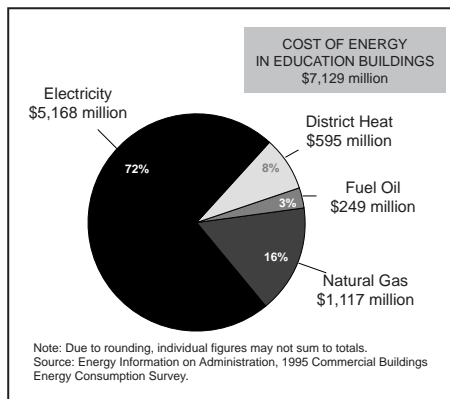

Energy Usage Characteristics of Educational Facilities

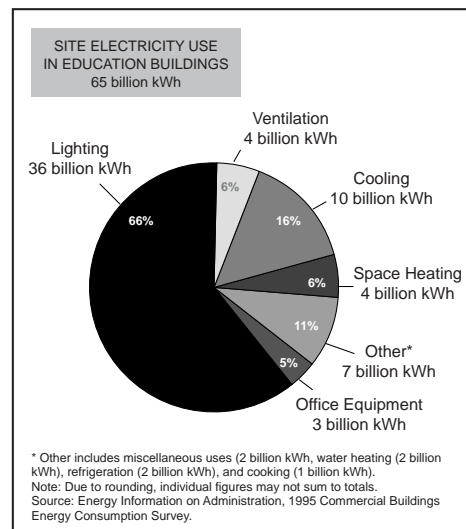

The use of lighting controls can reduce these expenditures significantly. Expected savings from the use of occupancy sensors in classrooms alone can range from 10-50%. These savings are realized simply by turning lighting off when the rooms are unoccupied and lighting is not necessary. Other lighting controls can reduce lighting energy usage as well. For instance, the EPA has estimated that the use of daylighting controls can result in savings ranging up to 40%. Perhaps most importantly, these savings can be realized without affecting the quality of educational activities or the efficacy of the learning environment.

K-12 School Space Usage

The types of facilities and spaces used in schools vary, depending upon the grade level of the institution. The pie chart below illustrates the average percentage of floor space for common space types found in K-12 facilities.

Space usage is an important consideration. Elementary and middle/high school classrooms, for instance, are primarily differentiated by the way the space is used. While often the teacher "owns" the classroom regardless of educational level, occupants and activities can vary depending on educational level. In elementary schools, occupants in a classroom generally remain the same throughout the school day while the educational activities change. At the middle/high school levels, however, students move between classrooms throughout the day while activities in each classroom remain similar.

These differences in space usage should be considered in the lighting controls decision. For instance, differences in space usage would impact a decision on the use of daylighting controls. Classrooms, where students are engaged in reading or computer work are better suited to the use of continuous dimming controls, while in hallways, where occupancy may be more transient and students are moving, would be well suited to ON/OFF daylight switching controls.

Space ownership plays an equally important role in the design and selection of lighting controls. In areas where ownership is strongest, manual overrides might be desirable. Common areas, where no single occupant or group of occupants is dominant, benefit more from purely automated control.

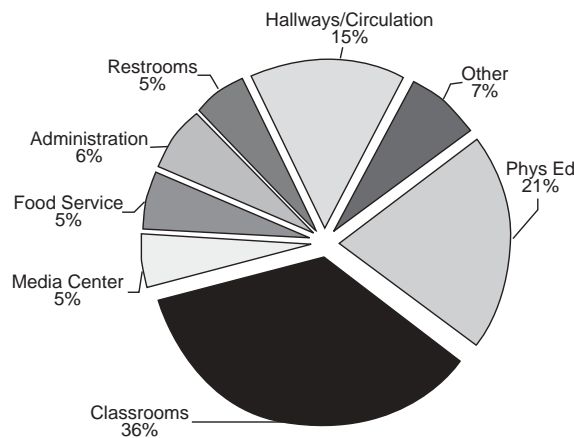

Average % of Floorspace by Space Type for Schools

School Design Guidelines

A well designed control system requires the consideration of energy codes, the occupants' and building owner's control needs, building use patterns and the type of lighting that's used in each space. Listed below are some general lighting control best practice principles for space types in schools.

General Considerations

- Mount occupancy sensors at least 6 to 8 ft away from HVAC ducts. Ultrasonic sensors should be mounted on vibration free, stable surfaces and should not be used in areas of heavy air flow, moving objects, or where the ceiling height is greater than 14 ft.
- If there is a concern that lighting could be turned off automatically or manually when people are still in a space, put in night lighting for safe egress.
- Use products that are durable and can resist abuse, such as stainless steel wall plates.
- Many lighting control devices have specific voltage and load rating requirements. Be sure to specify the device model that matches the correct voltage and load rating for the application.

Classrooms

- Dual technology occupancy sensors are used for classrooms because of their optimal performance. Classrooms with hanging artwork that can move due to air flow, should utilize passive infrared sensors.
- Mount occupancy sensors so there is no detection outside the door. They should be mounted close to the teacher's desk, above the main level of activity, and below fixture mounting heights. They should not be placed where they could be covered by artwork, shelves or other furniture.
- Always include switches that provide manual override control of the lighting.
- If daylight is available, provide daylight responsive, continuous dimming control.

Public Spaces/Common Areas

- Public spaces, such as hallways and restrooms, are best suited for automatic on/off control of lighting. If manual control is needed, use key operated switches or install switches in secured areas.
- If daylight is available, provide daylight responsive, stepped dimming control.

Gymnasiums/Multipurpose Rooms

- For spaces with HID lighting requiring a restrike period, it is best to use a control panel with time based on/off control. A more energy efficient design can be accomplished by using bi-level control of HID fixtures with occupancy sensors and time based control for shut off after hours.

Restrooms

- Ultrasonic sensors are the right choice for spaces such as restrooms with stalls even when there is no direct line of site of the occupant from the sensor.

Exterior

- Using a lighting control panel with time clock and photocell, control exterior lighting to turn on at dusk and off at dawn. Program the clock to turn non-security lighting off early for energy savings.

Influential Factors for Lighting Control

Energy Code Requirements

Energy code compliance varies from state to state. Many states are adopting the new ASHRAE 90.1-2001 standard, which requires automatic lighting shut-off in commercial buildings greater than 5000 square feet in individual spaces by using either time scheduling or occupancy sensors. Other states, such as California, have developed their own guidelines for lighting and other energy controls.

Safety and Security

Providing lighting when and where needed is a key factor of safety and security. In a public setting such as a school, security is of the utmost importance. Proper design and use of lighting controls is an integral part of addressing these concerns. Location and accessibility to manual controls, adequate night lighting, timely exterior lighting control, reliable system operation as well as other lighting control elements, all play a part in ensuring safety and security in schools.

Energy Efficiency and Sustainable Building Designs

With rising energy costs, making educational facilities operate as efficiently as possible is of increasing importance. Similarly, many new educational facilities are being designed using sustainable resource principles. These include architectural features, such as daylighting, and the use of building materials that are recyclable or environmentally benign.

Community Center Functions

Another trend that influences lighting and lighting control design is the increasing use of educational facilities as community centers for adult education and after-school programs. Extended and varying operating schedules alter the space usage, and impose additional needs for flexibility in lighting control.



Summary of Best Practices for Lighting Control in Schools

The table below summarizes the lighting control best practices for school spaces shown in this guide. These best practices address typical control needs in the most common space types. However, control needs will vary from project to project and with school type.

Although not described in this guide, many other areas in a school are ideal for lighting control including administrative offices, libraries, cafeterias, auditoriums, storage areas, field lighting, locker rooms, and more.

<i>Best Practice</i>	<i>Space</i>	<i>Best Practices Summary</i>
C1.0	Classroom	• occupancy sensing • manual override
C1.0.5	Classroom (hanging mobiles)	• occupancy sensing • manual override
C1.1	Classroom	• occupancy sensing • bi-level switching • manual override
C1.2	Classroom	• occupancy sensing • bi-level switching • manual override • daylighting (stepped dimming)
C2.0	Classroom (partitioned)	• occupancy sensing • manual override
C2.1	Classroom (partitioned)	• occupancy sensing • bi-level switching • manual override
C3.0	Classroom	• occupancy sensing • bi-level switching • manual override • daylighting (continuous dimming)
C3.1	Classroom (skylight)	• occupancy sensing • manual dimming • manual override • daylighting (continuous dimming)



Best Practice	Space	Best Practices Summary
G1.0	Gymnasium	• time scheduling • bi-level HID • night lighting • manual override
G1.1	Gymnasium	• time scheduling • bi-level HID • time switch • occupancy sensing • night lighting • manual override
G2.0	Gymnasium (partitioned)	• time scheduling • manual override
H1.0	Hallway, vestibule, lobby	• time scheduling • occupancy sensing
M1.0	Multipurpose room	• occupancy sensing • manual override • bi-level switching
R1.0	Large restroom	• occupancy sensing • manual override • fan control
R2.0	Small restroom	• occupancy sensing • manual override • fan control
R3.0	Faculty/individual restroom	• occupancy sensing • manual override • fan control
E1.0	Exterior lighting	• time scheduling • photocell • manual override

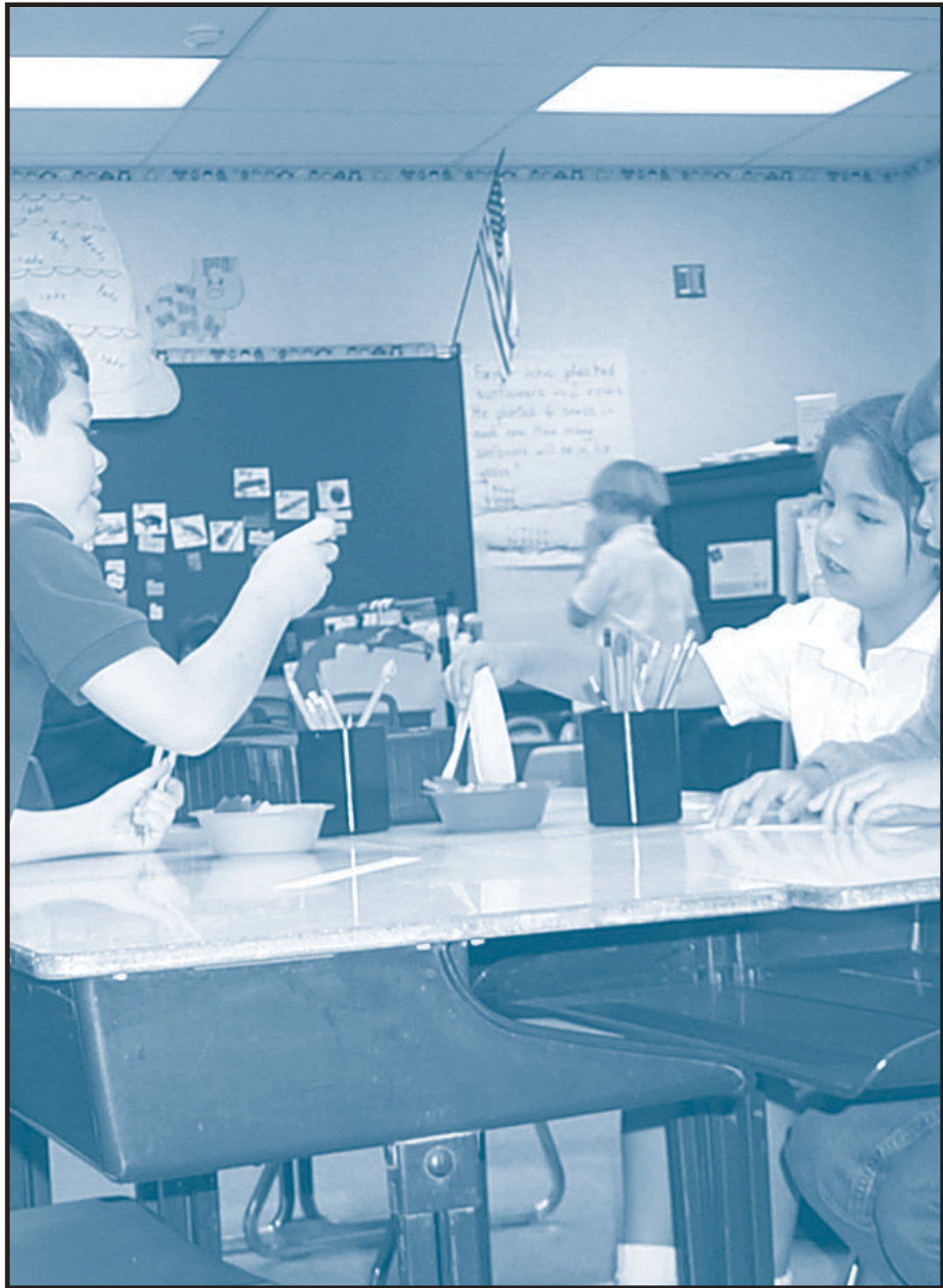

C1.0 Classroom: occupancy sensing

Control Needs	Solution	Application Description
Automatically turn lights ON/OFF based on occupancy	Corner-mounted dual technology occupancy sensor (DT series)	Space use: Classroom activities Dimensions: 28' x 30' Ceiling height: 10'
Manual override OFF	Wall switch	Windows: Windows along one wall providing view to exterior and ventilation
Occupancy-based control of HVAC system	Isolated relay on occupancy sensor	Window blinds: Horizontal blinds Skylights: None
		Lighting
		Pendant mounted indirect/direct luminaires with isolated center lamp optics using three T5 lamps and 2-lamp, tandem wired 277 volt electronic ballasts

Design Considerations

The DT-200 Dual Technology occupancy sensor automatically turns lights off when the classroom is unoccupied, and turns lights on upon occupancy. It is positioned near the teacher's desk to ensure detection when classes are not in session and the teacher is at the desk. The sensor is corner-mounted to prevent a view out the doorway that might otherwise result in false activations. A standard wall switch allows users to manually override lights off. In most classrooms, the DT Dual Technology occupancy sensor will provide the best coverage and detection. In cases where hanging objects exist, such as mobiles, artwork or teaching aids, a CX-100 passive infrared sensor should be used (see C1.0.5).

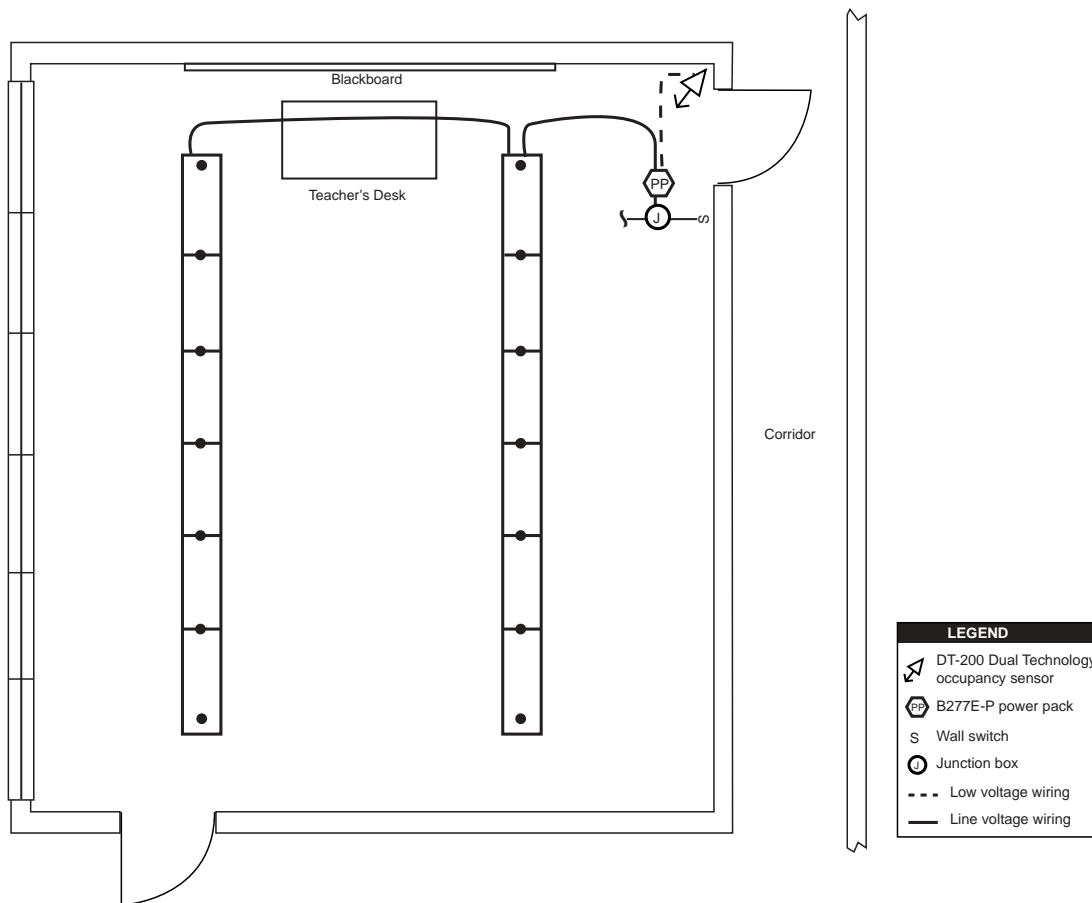

C1.0 Installation Notes

1. Mount DT-200 occupancy sensor at same height as luminaire so that sensor view is not blocked.
2. Mount DT-200 in corner and aim at opposing corner to provide a full view of the room but not the corridor.
3. DT-200 is shipped with a factory preset time delay of 18 minutes, the recommended minimum for classrooms and with sensitivity setting at maximum. Refer to installation instructions if adjustments are necessary.
4. Use a minimum of 22 gauge wire for low voltage wiring. See Technical Bulletin TB-124 on Voltage Loss at www.wattstopper.com.
5. Use stainless steel wall switch plates to facilitate cleaning and minimize damage from impact.
6. DT-200 sensor isolated relay can provide status information to the BAS and/or control HVAC loads.

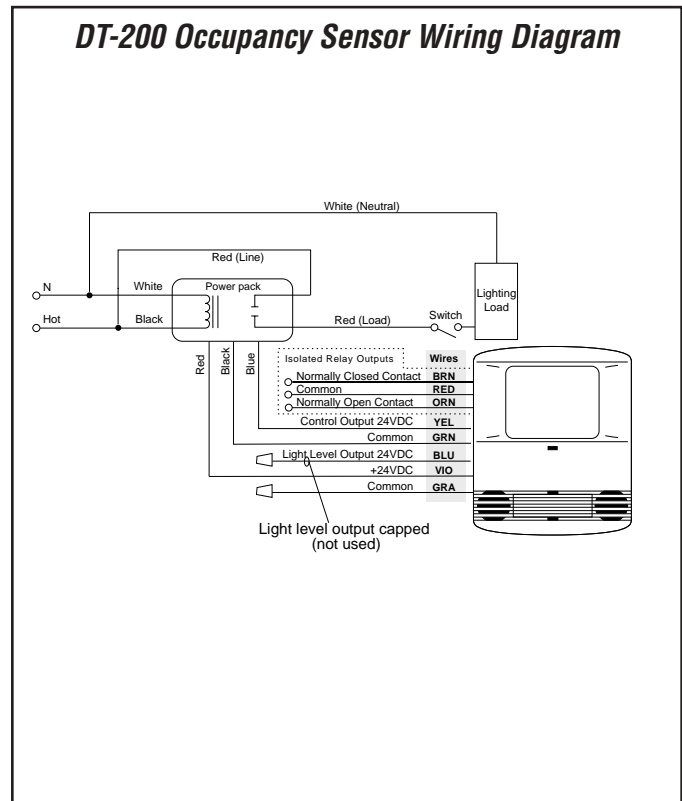
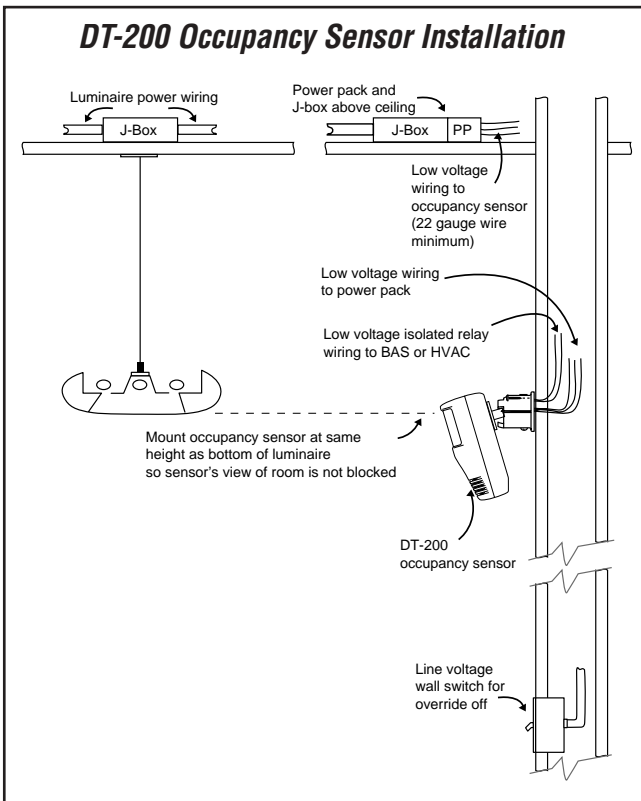

Equipment Schedule

Catalog No.	Qty	Description
DT-200	1	Dual technology occupancy sensor, isolated relay, wide angle lens
B277E-P	1	Power pack, 277 VAC, 60 Hz
AC1 Series	1	Wall switch, Pass & Seymour/legrand, AC1 series, single pole
SL1	1	Wall plate, Pass & Seymour/legrand, type 430, stainless steel finish, single-gang

C1.0.5 Classroom (hanging mobiles): occupancy sensing

Control Needs	Solution	Application Description
Automatically turn lights ON/OFF based on occupancy	Corner-mounted passive infrared occupancy sensor (CX series)	Space use: Classroom activities Dimensions: 28' x 30' Ceiling height: 10'
Manual override OFF	Wall switch	Windows: Windows along one wall providing view to exterior and ventilation
Occupancy-based control of HVAC system	Isolated relay on occupancy sensor	Window blinds: Horizontal blinds Skylights: None
		Lighting Pendant mounted indirect/direct luminaires with isolated center lamp optics using three T5 lamps and 2-lamp, tandem wired 277 volt electronic ballasts

Design Considerations

The CX-100 occupancy sensor automatically turns lights off when the classroom is unoccupied, and turns lights on upon occupancy. It is positioned near the teacher's desk to ensure detection when classes are not in session and the teacher is at the desk. The sensor is corner-mounted to prevent a view out the doorway that might otherwise result in false activations. A standard wall switch allows users to manually override lights off. While in most classrooms, the DT Dual Technology occupancy sensor will provide the best coverage and occupancy detection, the CX-100 passive infrared sensor is best for this application because of the presence of hanging objects.

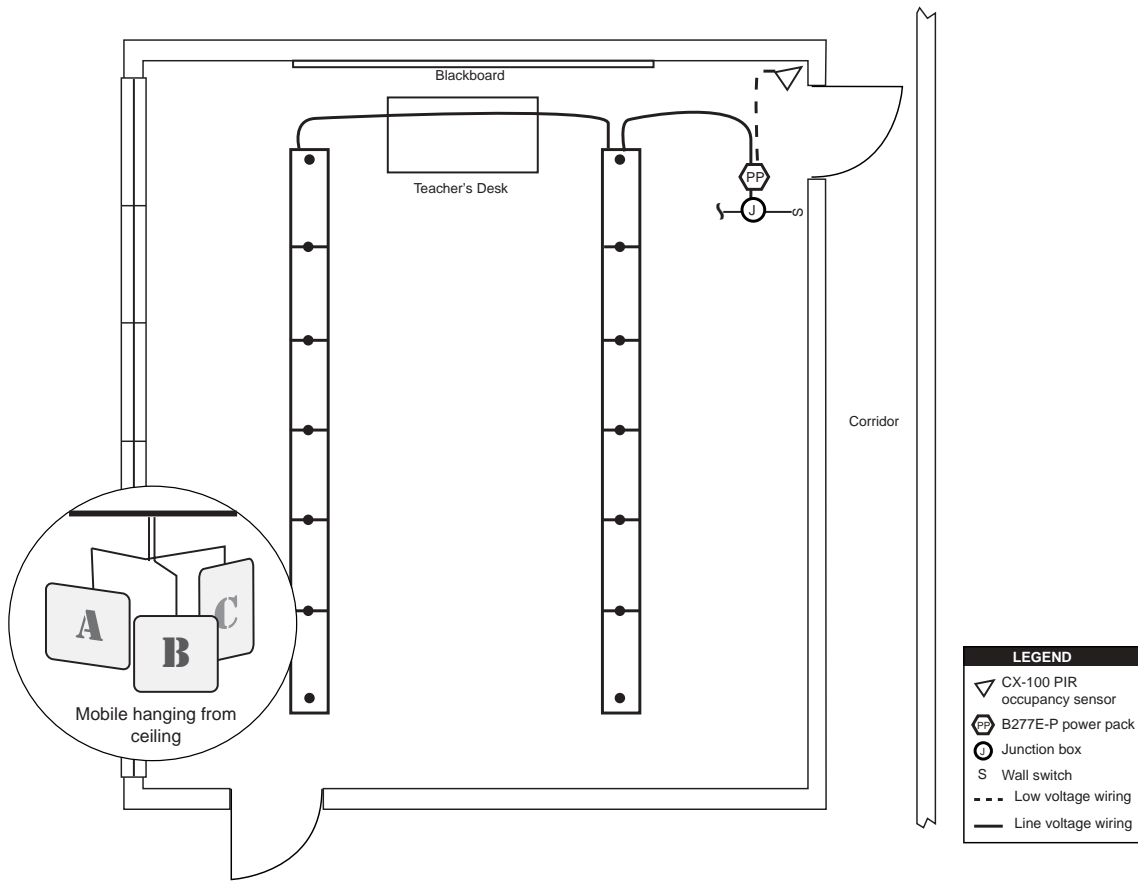

C1.0.5 Installation Notes

1. Mount CX-100 occupancy sensor at same height as luminaire so that sensor view is not blocked.
2. Mount CX-100 sensor in corner and aim at opposing corner to provide a full view of the room but not the corridor.
3. CX-100 is shipped with a factory preset time delay of 18 minutes, the recommended minimum for classrooms and with sensitivity setting at maximum. Refer to installation instructions if adjustments are necessary.
4. Use a minimum of 22 gauge wire for low voltage wiring. See Technical Bulletin TB-124 on Voltage Loss at www.wattstopper.com.
5. Use stainless steel wall switch plates to facilitate cleaning and minimize damage from impact.
6. CX-100 sensor isolated relay can provide status information to the BAS and/or control HVAC loads.

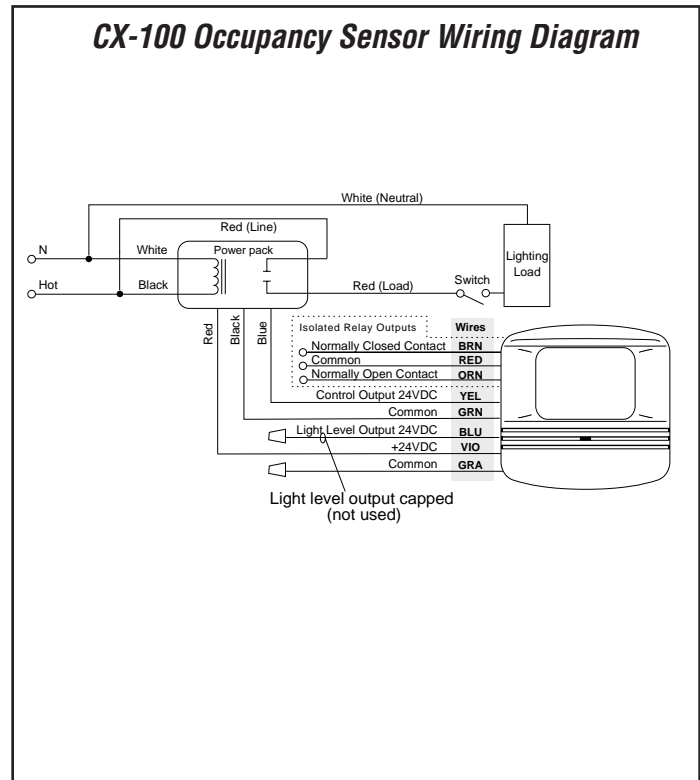
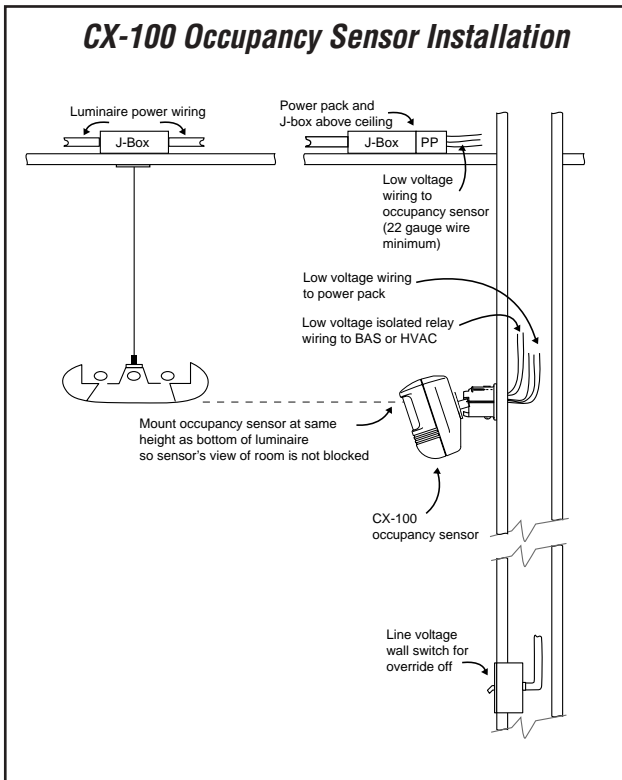

Equipment Schedule

Catalog No.	Qty	Description
CX-100	1	Passive infrared occupancy sensor, isolated relay, wide angle lens
B277E-P	1	Power pack, 277 VAC, 60 Hz
AC1 Series	1	Wall switch, Pass & Seymour/legrand, AC1 series, single pole
SL1	1	Wall plate, Pass & Seymour/legrand, type 430, stainless steel finish, single-gang

C1.1 Classroom: occupancy sensing • bi-level switching

Control Needs	Solution	Application Description
Automatically turn lights ON/OFF based on occupancy	Corner-mounted dual technology occupancy sensor (DT series)	Space use: Classroom activities Dimensions: 28' x 30' Ceiling height: 10'
Bi-level switching	Tandem-wired ballasts and wall switches	Windows: Windows along one wall providing view to exterior and ventilation Window blinds: Horizontal blinds Skylights: None
Manual override OFF	Wall switches	
Occupancy-based control of HVAC system	Isolated relay on occupancy sensor	

Lighting

Pendant mounted indirect/direct luminaires with isolated center lamp optics using three T5 lamps and 2-lamp, tandem wired 277 volt electronic ballasts

Design Considerations

The DT-200 Dual Technology occupancy sensor automatically turns lights off when the classroom is unoccupied, and turns lights on upon occupancy. It is positioned near the teacher's desk to ensure detection when classes are not in session and the teacher is at the desk. The sensor is corner-mounted to prevent a view out the doorway that might otherwise result in false activations. Two standard wall switches are used for overriding lights off, and for bi-level control, providing control of the center lamps in each luminaire independently of the outboard lamps. In most classrooms, the DT Dual Technology occupancy sensor will provide the best coverage and detection. In cases where hanging objects exist, such as mobiles, artwork or teaching aids, a CX-100 passive infrared sensor should be used (see C1.0.5).

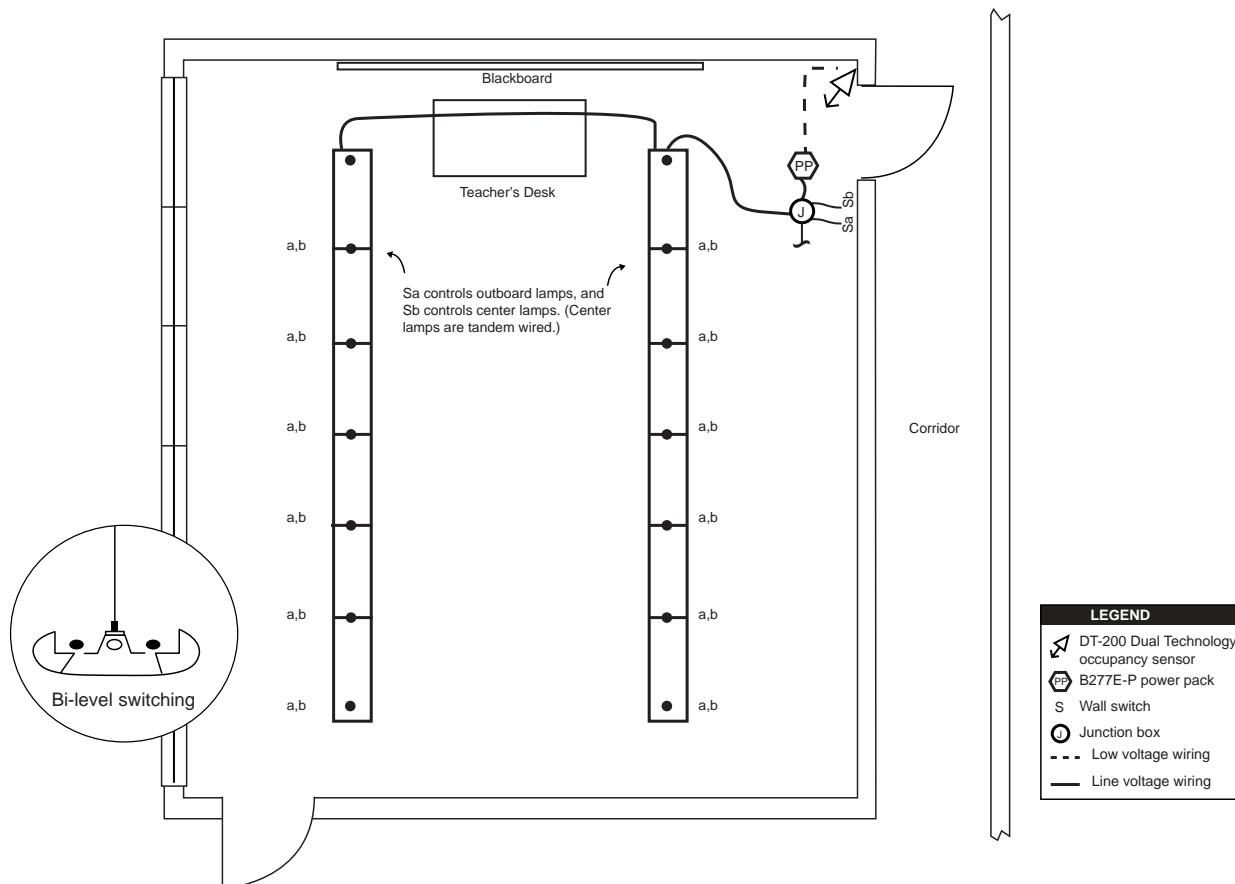

C1.1 Installation Notes

1. Mount DT-200 occupancy sensor at same height as luminaire so that sensor view is not blocked.
2. Mount DT-200 in corner and aim at opposing corner to provide a full view of the room but not the corridor.
3. DT-200 is shipped with a factory preset time delay of 18 minutes, the recommended minimum for classrooms and with sensitivity setting at maximum. Refer to installation instructions if adjustments are necessary.
4. Use a minimum of 22 gauge wire for low voltage wiring. See Technical Bulletin TB-124 on Voltage Loss at www.wattstopper.com.
5. Use stainless steel wall switch plates to facilitate cleaning and minimize damage from impact.
6. DT-200 sensor isolated relay can provide status information to the BAS and/or control HVAC loads.

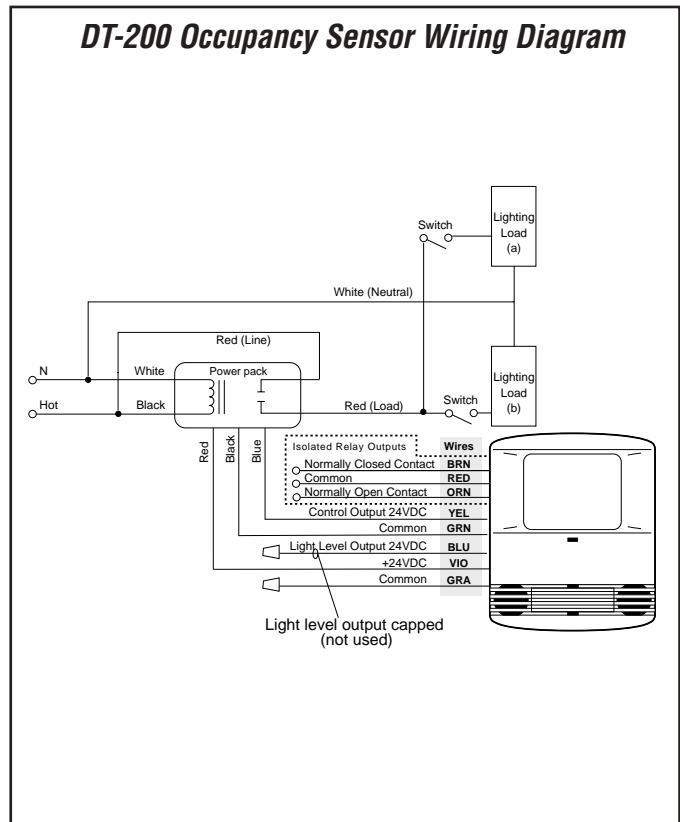
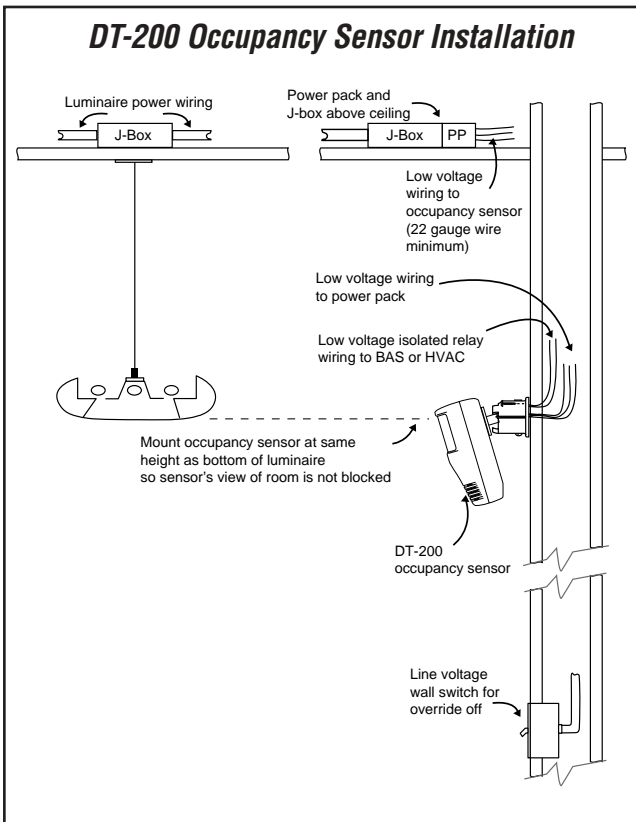

Equipment Schedule

Catalog No.	Qty	Description
DT-200	1	Dual technology occupancy sensor, isolated relay, wide angle lens
B277E-P	1	Power pack, 277 VAC, 60 Hz
AC1 series	2	Wall switch, Pass & Seymour/legrand, AC1 series, single pole
SL2	1	Wall plate, Pass & Seymour/legrand, type 430, stainless steel finish, two-gang

C1.2 Classroom: occupancy sensing • bi-level switching • daylighting

Control Needs	Solution	Application Description
Automatically turn lights ON/OFF based on occupancy	Corner-mounted dual technology occupancy sensor (DT series)	Space use: Classroom activities Dimensions: 28' x 30' Ceiling height: 10'
Bi-level switching	Tandem-wired ballasts and wall switches	Windows: Windows along one wall providing view to exterior and ventilation
Manual override OFF	Wall switches	Window blinds: Horizontal blinds Skylights: None
Light level ON/OFF control of row adjacent to window	Luminaire-mounted light level sensor controlling outboard lamps (uplight component) (LS-100)	
Occupancy-based control of HVAC system	Isolated relay on occupancy sensor	

Lighting

Pendant mounted indirect/direct luminaires with isolated center lamp optics using three T5 lamps and 2-lamp, tandem wired 277 volt electronic ballasts

Design Considerations

The DT-200 Dual Technology occupancy sensor automatically turns lights off when the classroom is unoccupied, and turns lights on upon occupancy. It is positioned near the teacher's desk to ensure detection when classes are not in session and the teacher is at the desk. The sensor is corner-mounted to prevent a view out the doorway that might otherwise result in false activations. An LS-100 light level sensor is used for turning off the outboard lamps in row 1 when enough daylight is present. Three manual wall switches are used for overriding lights off and for bi-level control, with center lamps in each luminaire controlled independently of the outboard lamps. In most classrooms, the DT Dual Technology occupancy sensor will provide the best coverage and occupancy detection. In cases where hanging objects exist, such as mobiles, artwork or teaching aids, a CX-100 passive infrared sensor should be used (see C1.0.5).

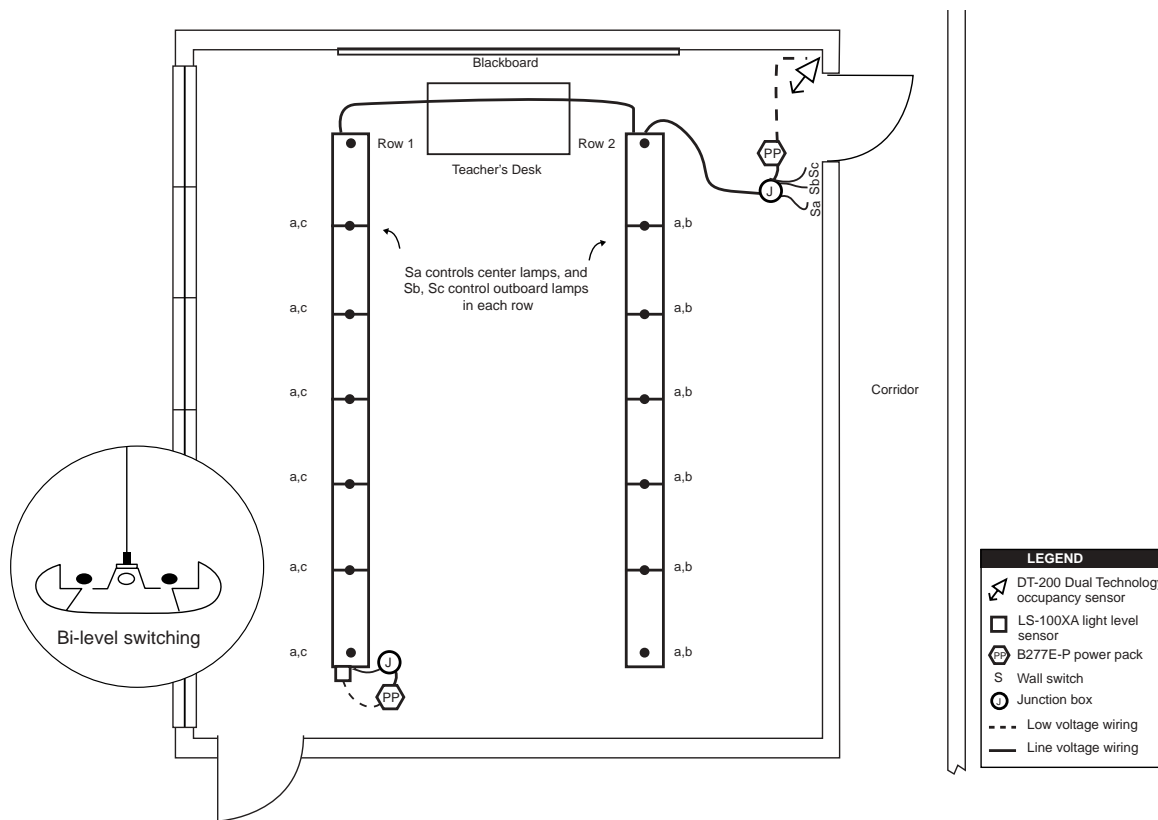

DT-200 Occupancy Sensor Installation

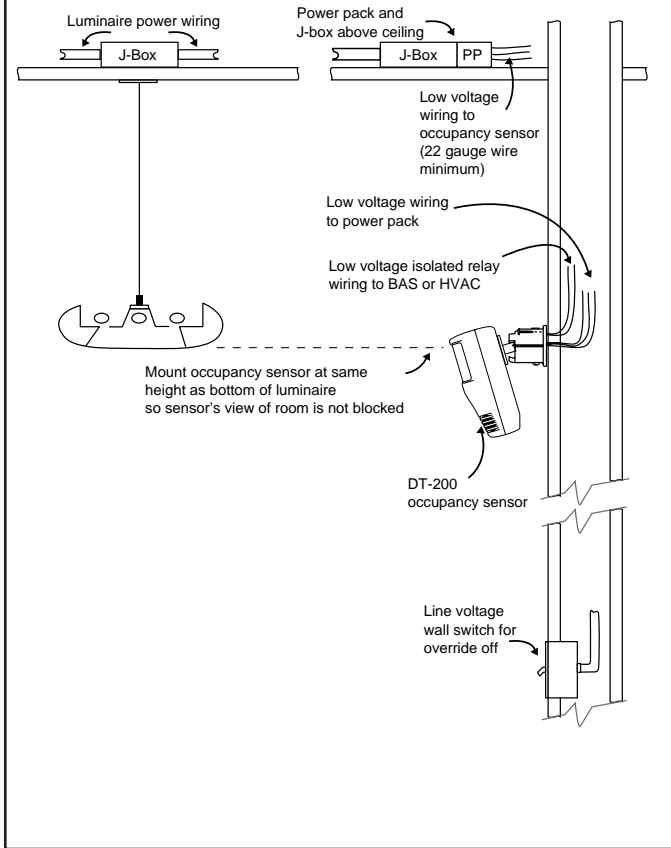

LS-100 Light Level Sensor Installation

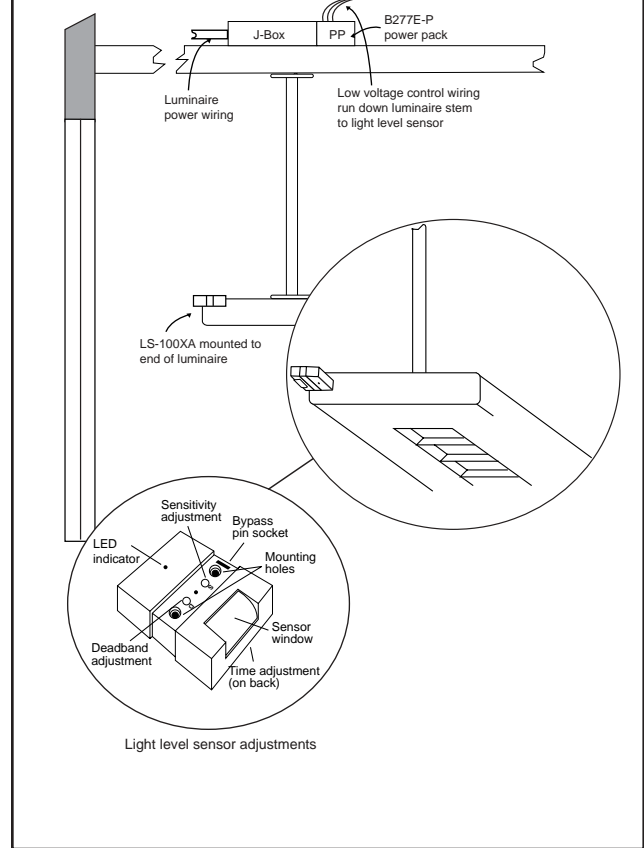

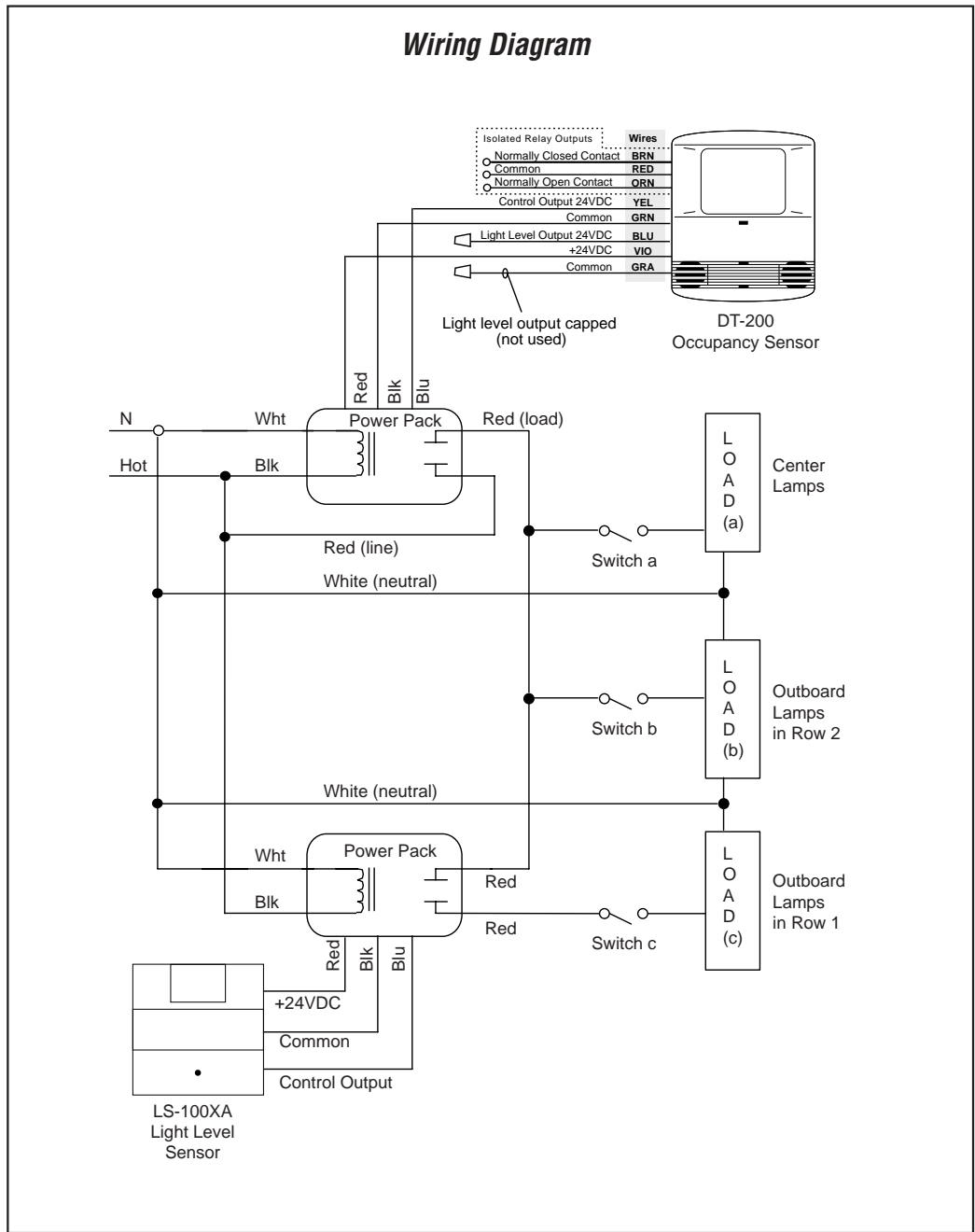

C1.2 Installation Notes

1. Mount DT-200 occupancy sensor at same height as luminaire so that sensor view is not blocked.
2. Mount DT-200 in corner and aim at opposing corner to provide a full view of the room but not the corridor.
3. DT-200 is shipped with a factory preset time delay of 18 minutes, the recommended minimum for classrooms and with sensitivity setting at maximum. Refer to installation instructions if adjustments are necessary.
4. Use a minimum of 22 gauge wire for low voltage wiring. See Technical Bulletin TB-124 on Voltage Loss at www.wattstopper.com.
5. Use stainless steel switch plates to facilitate cleaning and minimize damage from impact.
6. Mount LS-100 light level sensor to end of luminaire as shown on Light Level Sensor Installation drawing. Face lens toward window.
7. Follow the LS-100 installation instructions for setting the appropriate sensitivity and deadband levels.
8. DT-200 sensor isolated relay can provide status information to the BAS and/or control HVAC loads.

Equipment Schedule

Catalog No.	Qty	Description
DT-200	1	Dual technology occupancy sensor, isolated relay, wide angle lens
LS-100XA	1	Light level sensor, 10 - 200 footcandle range
B277E-P	2	Power pack, 277 VAC, 60 Hz
AC1 series	3	Wall switch, Pass & Seymour/legrand, AC1 series, single pole
SL3	1	Wall plate, Pass & Seymour/legrand, type 430, stainless steel finish, three-gang

C2.0 Partitioned Classroom: occupancy sensing

Control Needs	Solution	Application Description
Automatically turn lights ON/OFF based on occupancy	Corner-mounted dual technology occupancy sensor (DT series)	<p>Space use: Classroom activities. Space is partitioned and can be used either as one large classroom or two individual classrooms</p> <p>Dimensions: 28' x 60'</p> <p>Windows: Windows along one wall providing view to exterior and ventilation</p> <p>Window blinds: Horizontal blinds</p> <p>Skylights: None</p>
Manual override OFF	Low voltage wall switch	
Combined control of both rooms when partition is open, and separate control when partition is closed	Automatic Relay Pack (ARP-Net) with door control relay	
Occupancy-based control of HVAC system	Isolated relay on Automatic Relay Pack	
		<p>Lighting</p> <p>Pendant mounted indirect/direct luminaires with isolated center lamp optics using three T5 lamps and 2-lamp, tandem wired 277 volt electronic ballasts</p>

Design Considerations

The DT-200 Dual Technology occupancy sensors automatically turn lights off when the classroom is unoccupied, and turn lights on upon occupancy. Each sensor is positioned near a teacher's desk to ensure detection when a teacher is at the desk and classes are not in session. The sensors are corner-mounted to prevent a view out the doorway that might otherwise result in false activations. A low voltage wall switch in each partitioned area is used for manually overriding lights off. A door control relay and an Automatic Relay Pack (ARP-Net) are used for operating all lighting loads and switches together when the partition is open, and operating each room individually when the partition is closed. The ARP-Net powers the occupancy sensors, and switches the lighting loads. In most classrooms, the DT Dual Technology occupancy sensor will provide the best coverage and detection. In cases where hanging objects exist, such as mobiles, artwork or teaching aids, a CX-100 passive infrared sensor should be used (see C1.0.5).

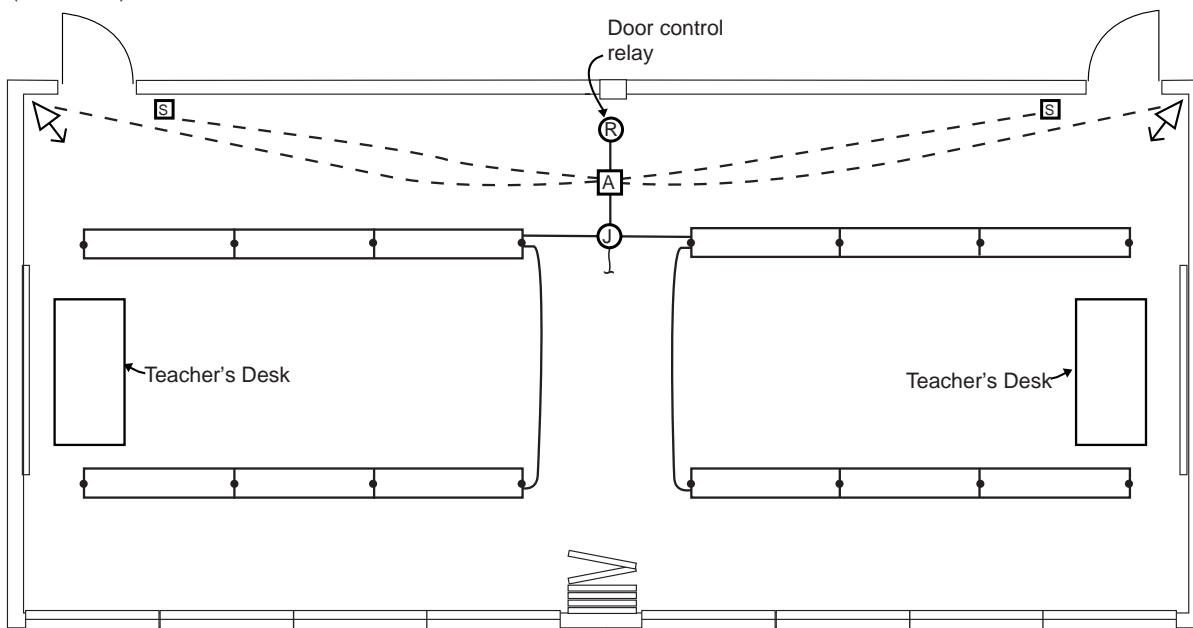

LEGEND	
	DT-200 Dual Technology occupancy sensor
	Door control relay
	ARP-Net Automatic Relay Pack
	Low voltage wall switch
	Junction box
	Low voltage wiring
	Line voltage wiring

C2.0 Installation Notes

1. Mount DT-200 occupancy sensor at same height as luminaire so that sensor view is not blocked.
2. Mount DT-200 in corner and aim at opposing corner to provide a full view of the room but not the corridor.
3. DT-200 is shipped with a factory preset time delay of 18 minutes, the recommended minimum for classrooms and with sensitivity setting at maximum. Refer to installation instructions if adjustments are necessary.
4. Locate the ARP-Net in an accessible ceiling space, or an accessible location close to the load (directly above the controlling switches if convenient). Mount the ARP-Net to a standard junction box using the provided 1/2" nipple and locknut.
5. Wire low voltage switches to the ARP-Net through the door control relay.
6. Do not directly connect conduit runs to low voltage section of the ARP-Net. Do not use ARP-Net's low voltage wiring compartment as a raceway or junction box for low voltage wiring.
7. Use a minimum of 22 gauge wire for low voltage wiring. See Technical Bulletin TB-124 on Voltage Loss at www.wattstopper.com.
8. ARP-Net isolated relays can provide status information to the BAS and/or control HVAC loads.
9. Use stainless steel switch plates to facilitate cleaning and minimize damage from impact.
10. Install door control relays in separate enclosure above ceiling. Connect door control switch to close relay when partition doors are opened.

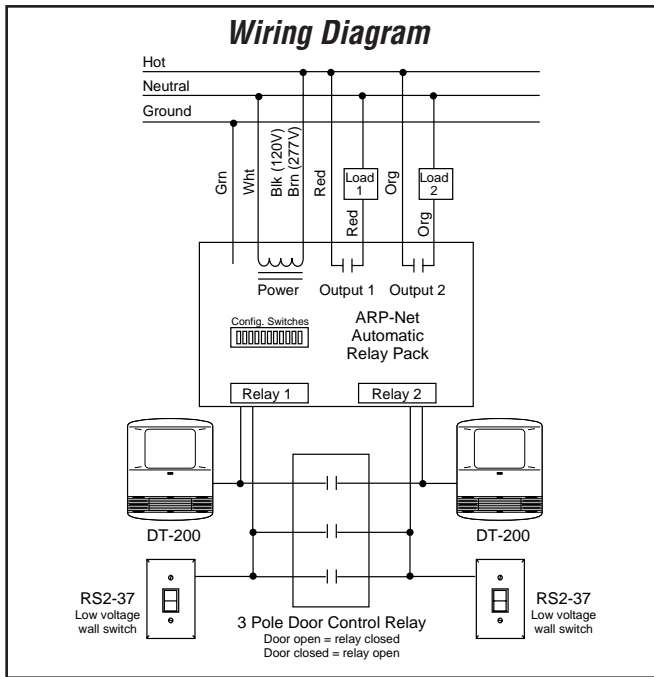
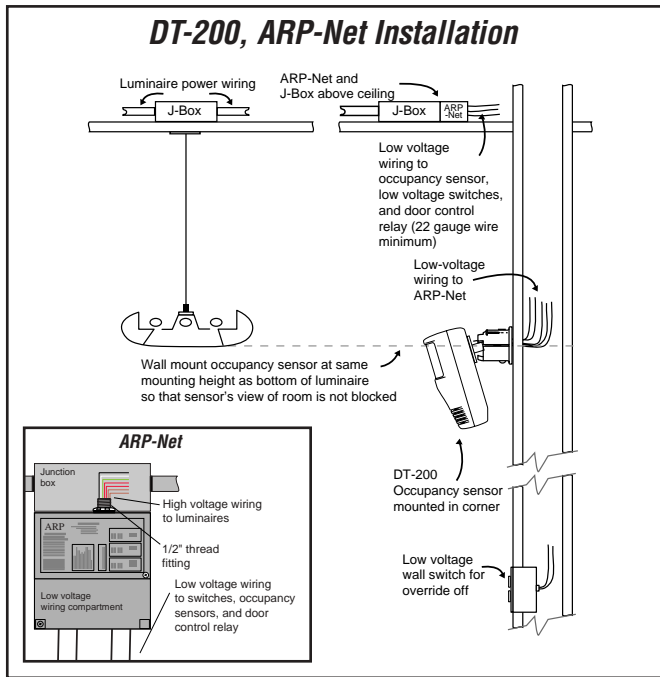

Equipment Schedule

Catalog No.	Qty	Description
DT-200	2	Dual technology occupancy sensor, isolated relay, wide angle lens
ARP-Net	1	Automatic Relay Pack, 120/277 VAC
RS2-37	2	2 button low voltage momentary switch, white
RP2-116	2	Wall plate, single-gang, stainless steel finish
RH3B-U-DC24V	1	Door control relay, 3-pole with 24 VDC coil, DIN rail mounted, Idec Corp. or equivalent
SH3B-05	1	Relay socket, Idec Corp. or equivalent

C2.1 Partitioned Classroom: occupancy sensing • bi-level switching

Control Needs	Solution	Application Description
Automatically turn lights ON/OFF based on occupancy	Corner-mounted dual technology occupancy sensor (DT series)	Space use: Classroom activities. Space is partitioned and can be used either as one large classroom or two individual classrooms
Bi-level switching	Tandem wired ballasts and wall switches	Dimensions: 28' x 60'
Manual override OFF	Low voltage wall switches	Ceiling height: 10'
Combined control of both rooms when partition is open, and separate control when partition is closed	Automatic Relay Pack (ARP-Net) with door control relay	Windows: Windows along one wall providing view to exterior and ventilation
Occupancy-based control of HVAC system	Isolated relay output on Automatic Relay Pack	Window blinds: Horizontal blinds
		Skylights: None
		Lighting
		Pendant mounted indirect/direct luminaires with isolated center lamp optics using three T5 lamps and 2-lamp, 277 volt electronic ballasts. Center lamps are tandem wired.

Design Considerations

The DT-200 Dual Technology occupancy sensors are used to automatically turn lights off when the classroom is unoccupied, and turn lights on upon occupancy. Each sensor is positioned near a teacher's desk to ensure detection when a teacher is at the desk and classes are not in session. The sensors are corner-mounted to prevent a view out the doorway that might otherwise result in false activations. A door control relay, low voltage wall switches, and Automatic Relay Packs (ARP-Net) are used for bi-level control, operating the center lamp and outboard lamps as two separate lighting groups in each room when the partition is closed. When the partition is open, the door control relay closes, and bi-level control of the center and outboard lamps is maintained for the entire space (from either switching location). The ARP-Net powers the occupancy sensors as well as switching the lighting loads. Low voltage switches are used for manually overriding lights off. In most classrooms, the DT Dual Technology occupancy sensor will provide the best coverage and detection. In cases where hanging objects exist, such as mobiles, artwork or teaching aids, a CX-100 passive infrared sensor should be used (see C1.0.5).

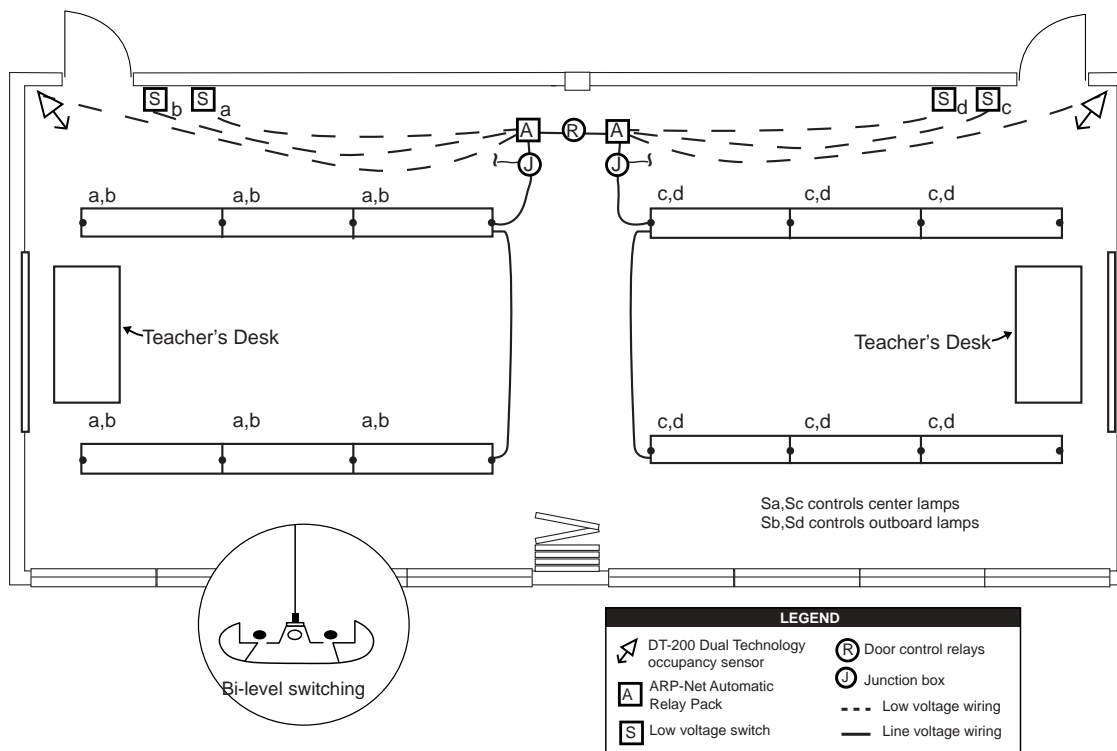

C2.1 Installation Notes

1. Mount DT-200 occupancy sensor at same height as luminaire so that sensor view is not blocked.
2. Mount DT-200 in corner and aim at opposing corner to provide a full view of the room but not the corridor.
3. DT-200 is shipped with a factory preset time delay of 18 minutes, the recommended minimum for classrooms and with sensitivity setting at maximum. Refer to installation instructions if adjustments are necessary.
4. Locate the ARP-Net in an accessible ceiling space, or an accessible location close to the load (directly above the controlling switches if convenient). Mount the ARP-Net to a standard junction box using the provided 1/2" nipple and locknut.
5. Wire low voltage switches to the ARP-Net through the door control relays.
6. Do not directly connect conduit runs to low voltage section of the ARP-Net. Do not use ARP-Net's low voltage wiring compartment as a raceway or junction box for low voltage wiring.
7. Use a minimum of 22 gauge wire for low voltage wiring. See Technical Bulletin TB-124 on Voltage Loss at www.wattstopper.com.
8. ARP-Net isolated relay can provide status information to the BAS and/or control HVAC loads.
9. Use stainless steel switch plates to facilitate cleaning and minimize damage from impact.
10. Install door control relays in separate enclosure above ceiling. Connect door control switch to close relay when partition doors are opened.

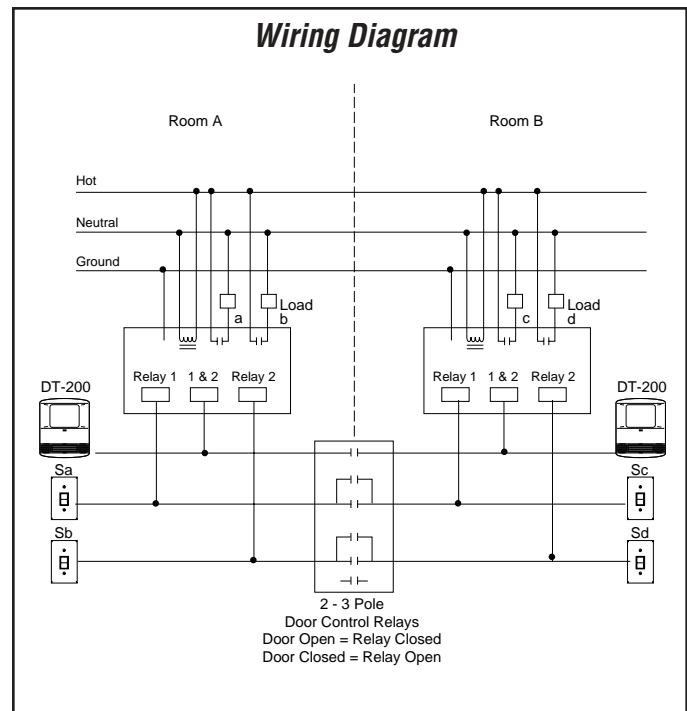
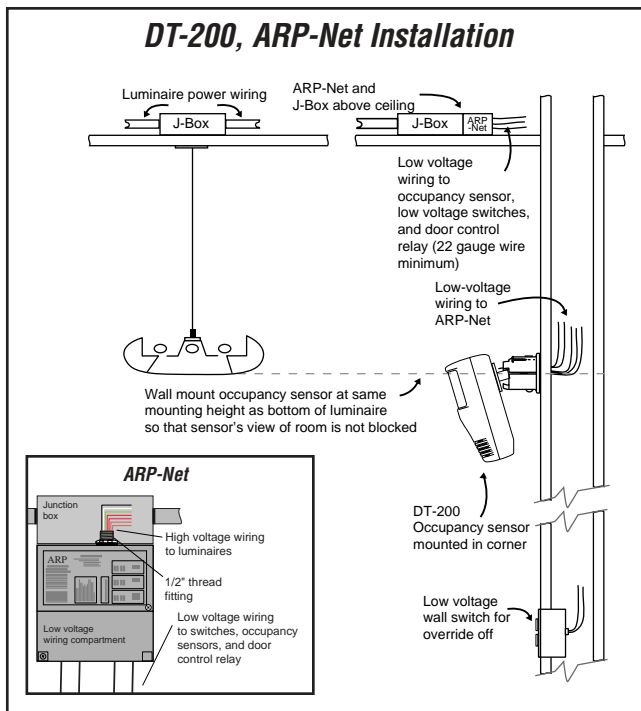

Equipment Schedule

Catalog No.	Qty	Description
DT-200	2	Dual technology occupancy sensor, isolated relay, wide angle lens
ARP-Net	2	Automatic Relay Pack, 120/277 VAC
RS2-36	4	2 button low voltage momentary switch, stainless steel finish
RP2-126	2	Wall plate, single-gang for 2 switches, stainless steel finish
RH3B--U-DC24V	2	Door control relay, 3-pole with 24 VDC coil, DIN rail mounted, Idec Corp. or equivalent
SH-3B-05	2	Relay socket, Idec Corp. or equivalent

C3.0 Classroom: occupancy sensing • bi-level switching • daylighting

Control Needs	Solution	Application Description
Automatically turn lights ON/OFF based on occupancy	Corner-mounted dual technology occupancy sensor (DT series)	Space use: Classroom activities Dimensions: 28' x 30' Ceiling height: 10'
Bi-level switching	Tandem wired ballasts and wall switches	Windows: Windows along one wall providing view to exterior and ventilation
Manual override OFF	Wall switches	Window blinds: Horizontal blinds Skylights: None
Automatically dim luminaire row parallel to windows	Ceiling mounted dimming light level sensor (LS-201)	Lighting Recessed 2'x4' fluorescent lensed luminaires using three T8 lamps with tandem wired ballasts; luminaires by window have 0-10 VDC dimming ballasts
Occupancy-based control of HVAC system	Isolated relay on occupancy sensor	

Design Considerations

The DT-200 Dual Technology occupancy sensor is used to automatically turn lights off when the room is unoccupied, and turn lights on upon occupancy. It is positioned near the teacher's desk to ensure detection when classes are not in session and the teacher is at the desk. The sensor is corner-mounted to prevent a view out the doorway that might otherwise result in false activations. An LS-201 dimming light level sensor, mounted on the ceiling, dims the lamps in the row parallel to the window when enough daylight is present. Two wall switches are used to manually override lights off and for bi-level control, operating the center lamps independently from the outboard lamps. In most classrooms, the DT Dual Technology occupancy sensor will provide the best coverage and detection. In cases where hanging objects exist, such as mobiles, artwork or teaching aids, a CX-100 passive infrared sensor should be used (see C1.0.5).

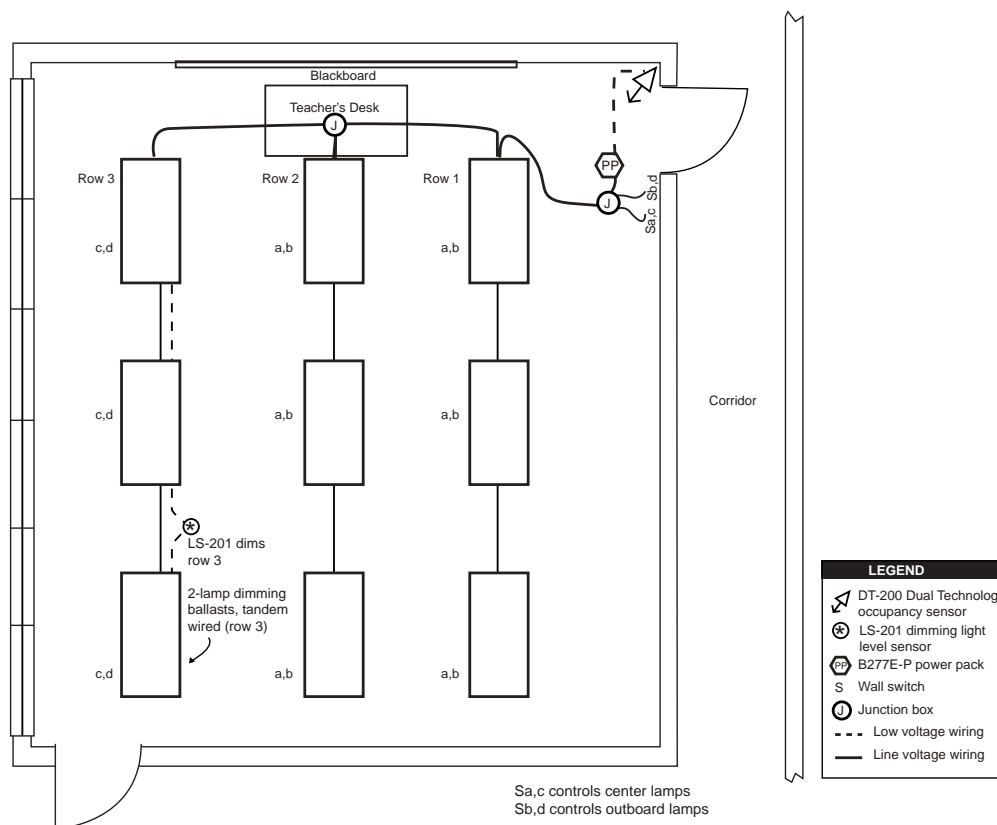

C3.0 Installation Notes

1. Mount DT-200 in corner and aim at opposing corner to provide a full view of the room but not the corridor.
2. DT-200 is shipped with a factory preset time delay of 18 minutes, the recommended minimum for classrooms and with sensitivity setting at maximum. Refer to installation instructions if adjustments are necessary.
3. Use a minimum of 22 gauge wire for low voltage wiring. See Technical Bulletin TB-124 on Voltage Loss at www.wattstopper.com.
4. Use stainless steel switch plates to facilitate cleaning and minimize damage from impact.
5. Mount LS-201 dimming light level sensor between 5 and 8 feet from the window wall for optimum operation.
6. Follow installation instructions for LS-201 light level sensor set-up guidelines.
7. DT-200 sensor isolated relay can provide status information to the BAS and/or control HVAC loads.

DT-200, LS-201 Wiring Diagram

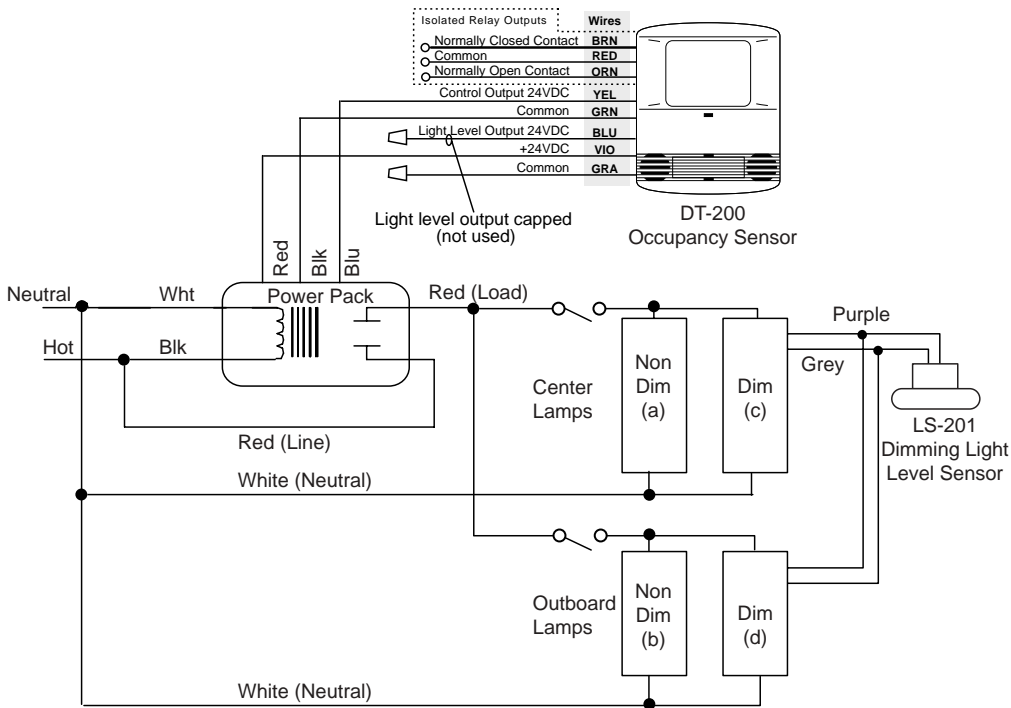

Equipment Schedule

Catalog No.	Qty	Description
DT-200	1	Dual technology occupancy sensor, isolated relay, wide angle lens
LS-201	1	LightSaver dimming light level sensor, 0-10 VDC, 60 degree field of view, 15 to 70 fc range
B277E-P	1	Power pack, 277 volt, 60 Hz
AC1 Series	2	Wall switch, Pass & Seymour/legrand, AC1 series, single pole
SL2	1	Wall plate, Pass & Seymour/legrand, type 430, stainless steel finish, two-gang

C3.1 Classroom (skylight): occupancy sensing • daylighting • manual dimming

Control Needs	Solution	Application Description
Automatically turn lights OFF when unoccupied	Corner-mounted dual technology occupancy sensor (DT series)	Space use: Classroom activities Dimensions: 28' x 30' Ceiling height: 10'
Manual ON/OFF and dim control	Manual dimmer/override switch (LS-4)	Windows: Windows along one wall providing view to exterior and ventilation Window blinds: Horizontal blinds
Dim luminaires based upon available daylight	Daylight dimming controller with photocell mounted in skylight well (LCD series)	Skylights: Two overhead skylights

Lighting

Pendant mounted indirect/direct luminaires with isolated center lamp optics using three T8 lamps and with 3-lamp 0-10 VDC electronic dimming ballast

Design Considerations

The LCD dimming system is used to automatically dim lights based on available daylight. The LS-190C photocell reads light levels at the skylight and provides this information to the LCD control module, which raises or lowers light output accordingly. The LS-4 dimming wall switch allows users to manually dim or turn lights on and off. The DT-200 Dual Technology occupancy sensor is used to automatically turn lights off when the room is unoccupied, and turn lights on upon occupancy. It is positioned near the teacher's desk to ensure detection when classes are not in session and the teacher is at the desk. The sensor is corner-mounted to prevent a view out the doorway that might otherwise result in false activations. In most classrooms, the DT Dual Technology occupancy sensor will provide the best coverage and detection. In cases where hanging objects exist, such as mobiles, artwork or teaching aids, a CX-100 passive infrared sensor should be used (see C1.0.5).

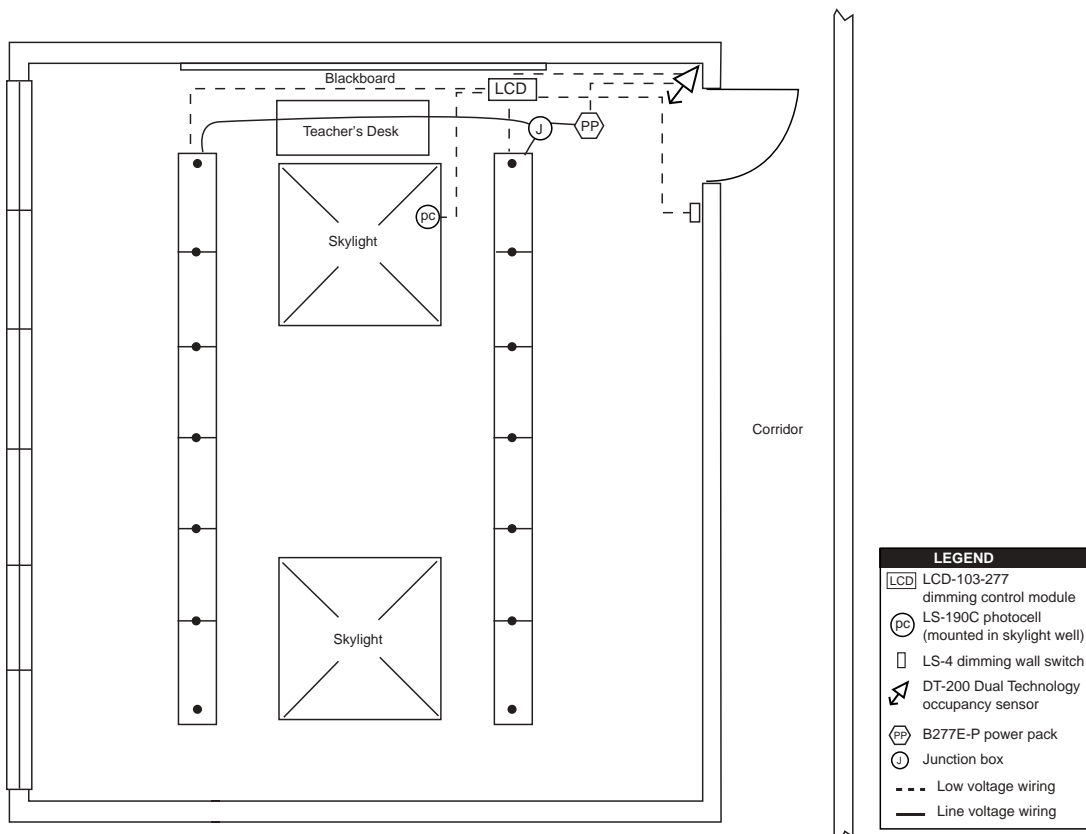

DT-200, LCD System Installation

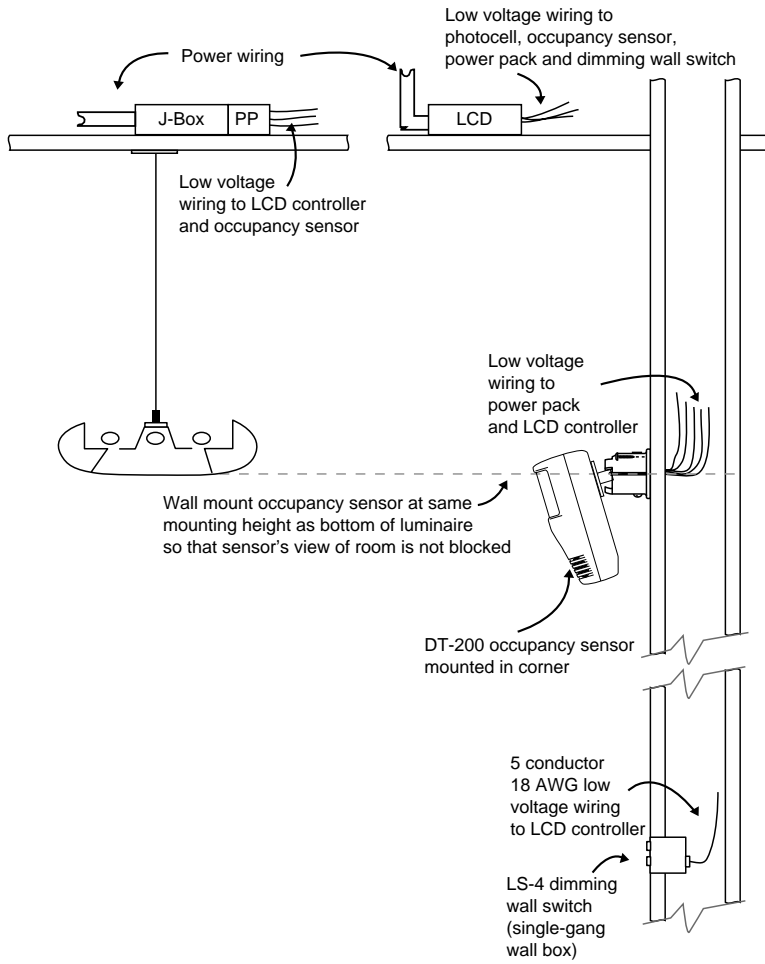

LCD Skylight Application

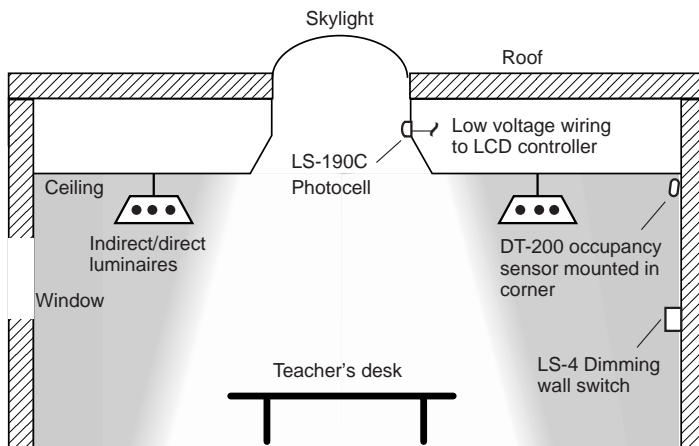

LCD System, DT-200 Occupancy Sensor Wiring Diagram

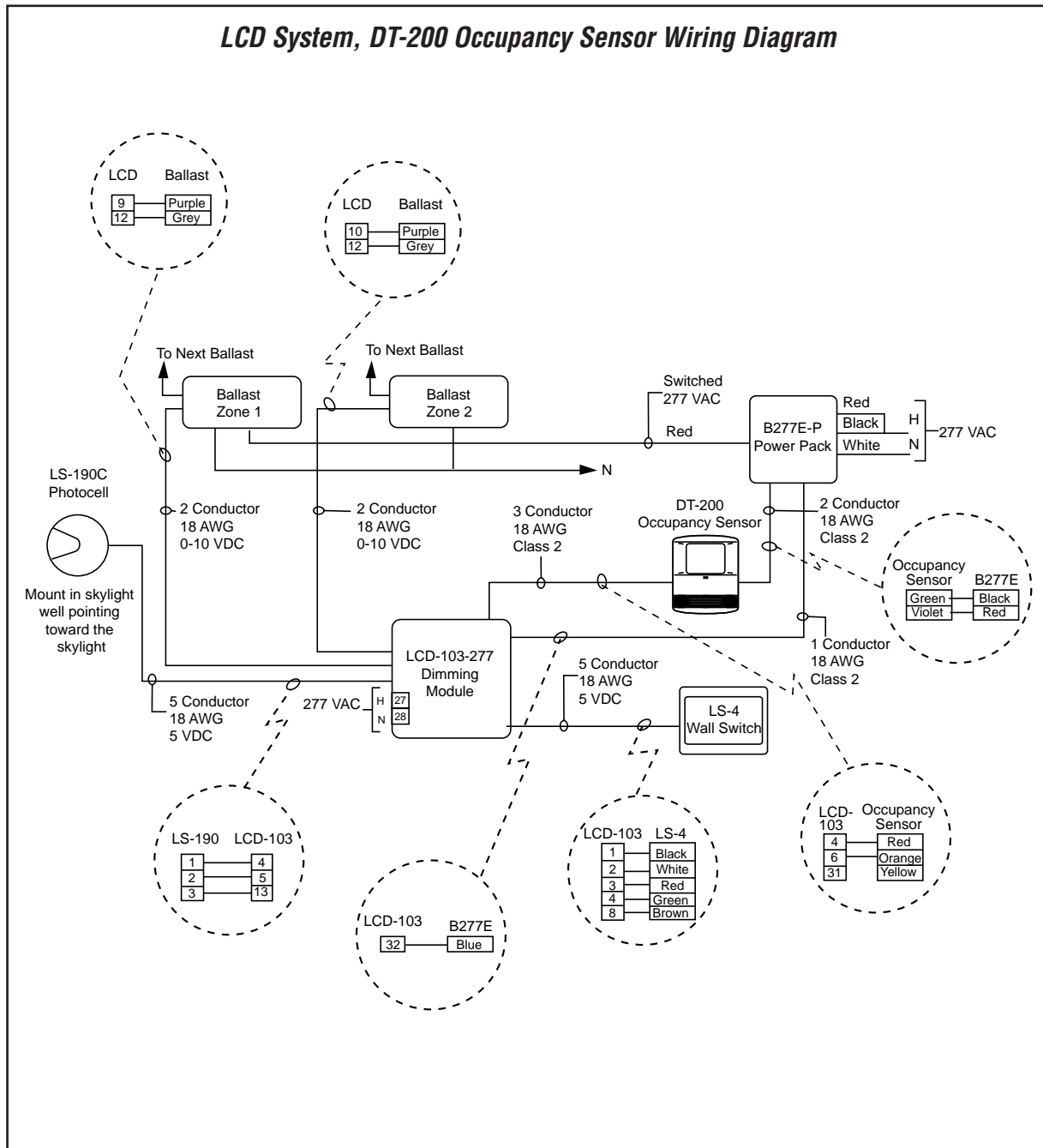

C3.1 Installation Notes

1. Mount DT-200 occupancy sensor at same height as luminaire so that sensor view is not blocked.
2. Mount DT-200 in corner and aim at opposing corner to provide a full view of the room but not the corridor.
3. DT-200 is shipped with a factory preset time delay of 18 minutes, the recommended minimum for classrooms and with sensitivity setting at maximum. Refer to installation instructions if adjustments are necessary.
4. Use a minimum of 22 gauge wire for low voltage wiring. See Technical Bulletin TB-124 on Voltage Loss at www.wattstopper.com.
5. Mount the LS-190C photocell in the skylight well pointing up. Position to have an unobstructed view of the incoming light from the skylight.
6. Use dimming response worksheet provided with the LCD system to set-up and calibrate the system.
7. Use the FX-200 Illuminometer digital light meter for taking illuminance measurements during system set-up and calibration.

Equipment Schedule

Catalog No.	Qty	Description
DT-200	1	Dual technology occupancy sensor, isolated relay, wide angle lens
B277E-P	1	Power pack, 277 volt, 60 Hz
LCD-103-277	1	LightSaver dimming control module, 277 volt, three zones
LS-190C	1	Photocell, 30-3000 footcandle range
LS-4	1	Dimming wall switch
LS-E8	1	Screw cover enclosure for the LCD control module, 8"x8"x4"
FX-200	1	Digital light meter, liquid crystal display, automatic zero adjustment (commissioning tool)

G1.0 Gymnasium: time scheduling • bi-level HID

Control Needs	Solution	Application Description
Schedule ON and OFF (7 AM - 4 PM)	Time clock in Smartwired lighting control panel	Space use: Physical education classes during school hours; team practices after school; basketball and volleyball some evenings; space is unlocked during the day. Dimensions: 110' x 120' Ceiling height: 28' Windows: None Window blinds: None Skylights: None
Manual override ON with automatic OFF for after hour events	Low voltage keyed switch and time clock in Smartwired lighting control panel	
Night light luminaires at low level when gym lighting is OFF	Time clock in Smartwired lighting control panel and bi-level HID control module (DM-100)	
Night lights operate during power outage	Power night lights from emergency panel	
		Lighting
		Pendant mounted prismatic low-bay metal halide luminaires using 350 watt pulse start lamps. Luminaires are mounted 24' above finished floor.

Design Considerations

The gymnasium lighting is scheduled on in the morning and off after school hours using a Smartwired lighting control panel with a time clock. Because the gymnasium may have transient occupancy and pass-through traffic throughout the day, lighting remains on until 4pm. For after hour events, 4 keyed switches (one at each entrance) provide users with a manual on override. The time clock in the panel provides the automatic shut off of this override after 4 hours. In addition, four of the HID luminaires are circuited for night and emergency lighting. These luminaires are controlled with a DM-100 bi-level control module which keeps the lighting at low level (50%) when regular gym lighting is off (and at full level when gym lighting is on). These 4 luminaires will also remain on, at low level, during a power outage. For information about controlling the emergency lighting through the lighting control panel, see G1.1.

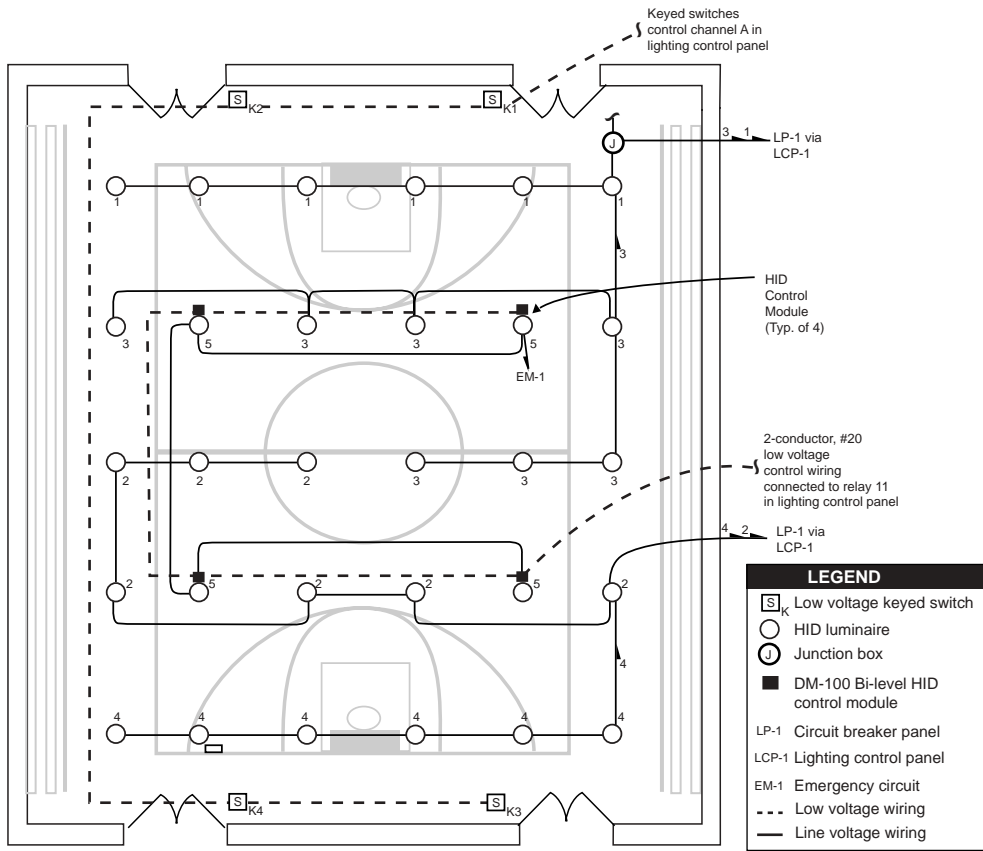

DM-100 Bi-level HID Controller Installation with Integral Ballast

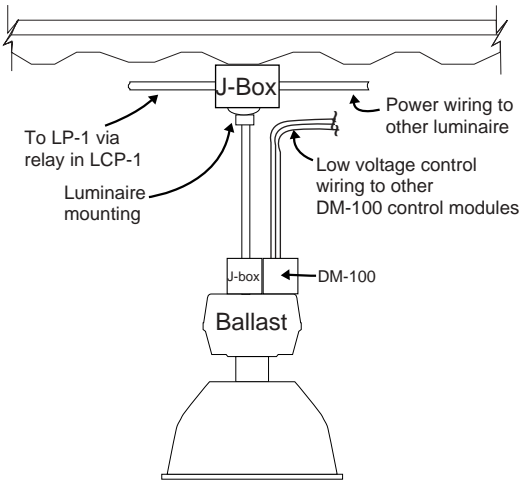

DM-100 Bi-level HID Controller Installation with Remote Ballast

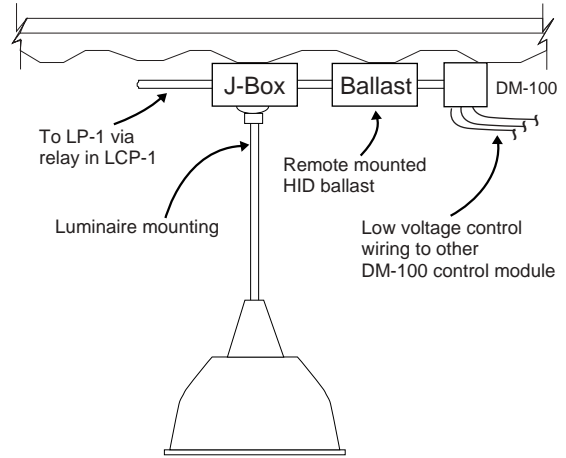

Typical CWA Ballast Wiring

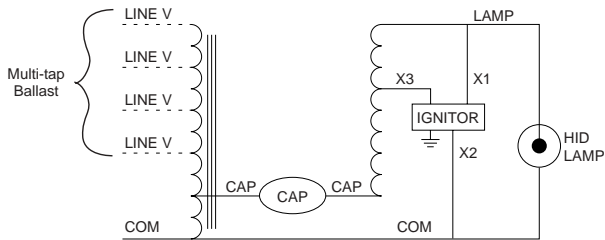

Typical CWA Ballast Wiring using DM-100

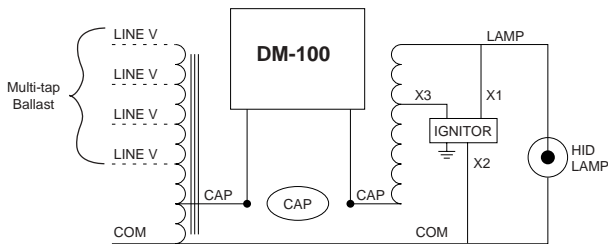

Drawings show typical wiring for Pulse Start and HPS lamps

DM-100 Wiring Diagram

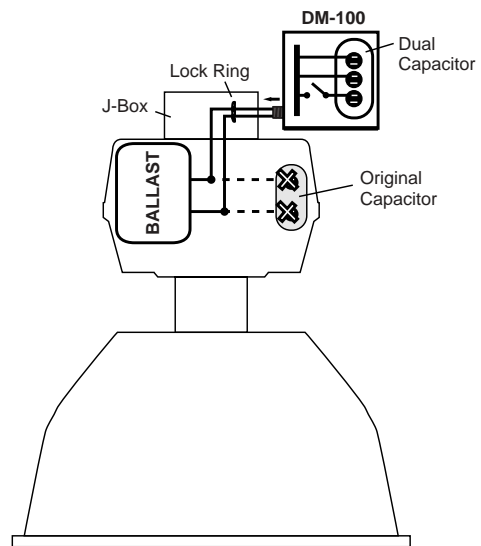

DM-100 Control Wiring

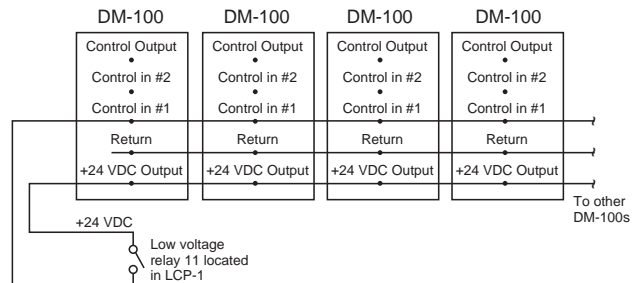

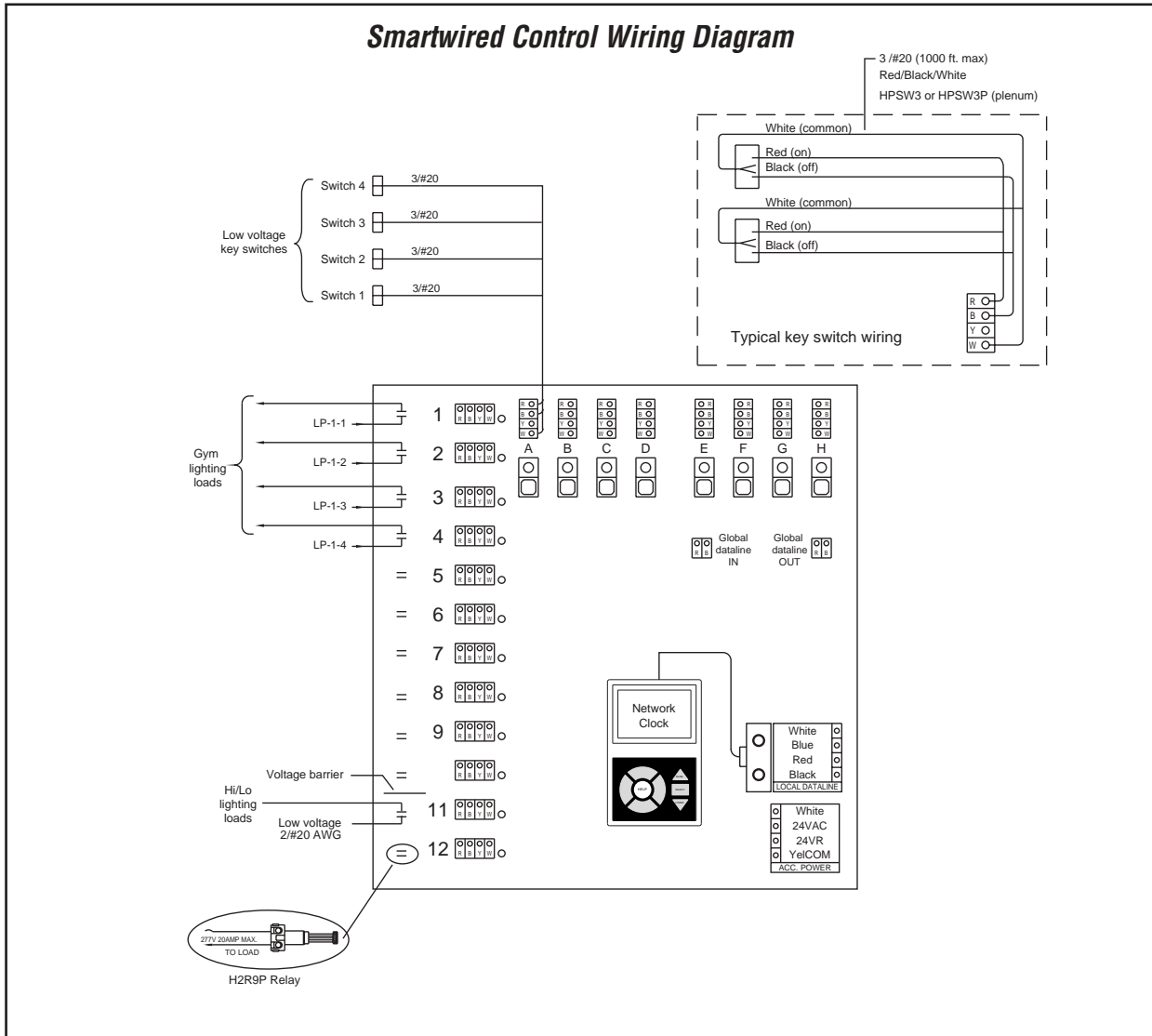

Panel Documentation

SMARTWIRED SWITCHING SYSTEM PANEL NUMBER LRP-1

RELAY SCHEDULE

Note: Check those relays which are controlled by automation channel under that channel letter box (Each relay can only be associated with one channel)

RELAY NUMBER	CIRCUIT #	LOAD DESCRIPTION	AUTOMATION CHANNEL					
			A	B	C	D	E	F
-01	LP-1-1	Gymnasium lights - north	X					
-02	LP-1-2	Gymnasium lights - north center	X					
-03	LP-1-3	Gymnasium lights - south center	X					
-04	LP-1-4	Gymnasium lights - south	X					
-05								
-06								
-07								
-08								
-09								
-10								
-11	DM wiring	Night lights - Hi/Lo	X					
-12								
-13								
-14								

SMARTWIRED SWITCHING SYSTEM NETWORK CLOCK AUTOMATION

CHANNEL	DESCRIPTION OF GROUP	AUTOMATION SCENARIO	DATA
A	Gymnasium lighting	<input checked="" type="checkbox"/> SCHEDULED ON/OFF	On: 7 am Off: 4 pm M-F
		<input type="checkbox"/> MANUAL ON/SCHEDULED OFF	No blink warn
		<input type="checkbox"/> MANUAL ON/SWEEP AUTO SW	Timed override: 240 min.
		<input type="checkbox"/> ASTRO (DARK) ON/OFF	
B		<input type="checkbox"/> ASTRO (DARK) ON/SCHED OFF	
		<input type="checkbox"/> SCHEDULED ON/LOW	
		<input type="checkbox"/> MANUAL ON/SCHEDULED OFF	
		<input type="checkbox"/> MANUAL ON/SWEEP AUTO SW	
		<input type="checkbox"/> ASTRO (DARK) ON/OFF	
		<input type="checkbox"/> ASTRO (DARK) ON/SCHED OFF	

Scenario

Scheduled ON/OFF

- ON/OFF times for each day of the week and holidays
- Blink warn (YES/NO)
- Timed override duration (1-240)

Manual ON/Scheduled OFF

- Same as above except ON/OFF replaced with Open 00:00 thru 00:00

Manual ON/Sweep Auto SW

- Occupied/unoccupied times for each day of week & holidays

G1.0 Installation Notes

1. Refer to Smartwired Switching System Installation and Operation Summary for detailed installation and operation instructions of the lighting control panel.
2. Commission the time clock according to the Network Clock Automation Scenarios documentation, and test the operation after commissioning.
3. Assign relays to the channels as shown on the Smartwired Relay schedule.
4. Test the operation of lighting control panels and key switches after installation.
5. Use stainless steel switch plates to facilitate cleaning and minimize damage from impact.
6. Confirm night light/egress lighting requirement with local code officials.

Equipment Schedule

Catalog No.	Qty	Description
HIN12R12SP	1	Smartwired Control lighting control panel interior, 12 relays
HTUB12	1	Tub enclosure for lighting control panel, up to 12 relays, 16"x16.5"x4.5"
HCVR12SL	1	Surface mounted cover for lighting control panel, up to 12 relays, 16.28"x16.7"x.75"
HCLK8SS	1	Network clock/programmer for Smartwired Control lighting control panel
HPSM115/277	1	Power supply for lighting control panel, 115/277 VAC, 50/60 Hz
DM-100-350MP	4	Bi-level HID control module, for 350-watt pulse start lamp operated by a CWA ballast
LVS-1K	4	Low voltage key switch, single-pole, double-throw momentary operation (key supplied with switch)
SL1	4	Wall plate, Pass & Seymour/legrand, type 430, stainless steel finish, single-gang

G1.1 Gymnasium: time scheduling • bi-level HID • time switch • occupancy sensing

Control Needs	Solution	Application Description
Schedule luminaires ON and OFF (7AM - 4PM)	Time clock in Smartwired lighting control panel	<p>Space use: Physical education classes during school hours, team practices after school; competitive basketball and volleyball some evenings; space is unlocked during unoccupied times of the day</p> <p>Dimensions: 110' x 120'</p> <p>Ceiling height: 28'</p> <p>Windows: None</p> <p>Window blinds: None</p> <p>Skylights: None</p> <p>Lighting</p> <p>Pendant mounted prismatic low-bay metal halide luminaires using 350 watt pulse start lamps. Luminaires are mounted 24' above finished floor.</p>
Low-level lighting when space is unoccupied; high-level (full) when space is occupied	Occupancy sensors with bi-level HID control module (CI sensors, DM-100)	
Manual override ON (full lighting) for after hour events	Time switch	
Manual override ON (full lighting) for custodial cleaning	Low voltage keyed switches and time clock in Smartwired lighting control panel	
Night light luminaires at low level when gym lighting is OFF	Bi-level HID control module (DM-100) and time clock in Smartwired control panel	
Night lights operate during power outage	Power night lights from emergency panel	
Manual override OFF night lighting for events	Low voltage keyed switches	

Design Considerations

The gymnasium lighting is scheduled on in the morning and off after school hours using a Smartwired lighting control panel with a time clock. Using CI-205 passive infrared occupancy sensors and DM-100 HID control modules, the lighting is reduced to half level when the gym is unoccupied, and returned to full light output when the gym is occupied during normal school hours (7am to 4pm). A time switch, located in the PE office, provides a manual on override of all luminaires to 100% for after hour events. One set of low voltage keyed switches, located at each entry, provide local manual on override for custodians. The time clock in the panel provides the automatic shut off of this override after 4 hours. In addition, four of the HID luminaires are circuited for night and emergency lighting. These luminaires are kept at low level when regular gym lighting is off (and at full level when gym lighting is on). These 4 luminaires will also remain on, at low level, during a power outage. The second set of key switches overrides the night/emergency lighting so that lights can be turned off if needed for events.

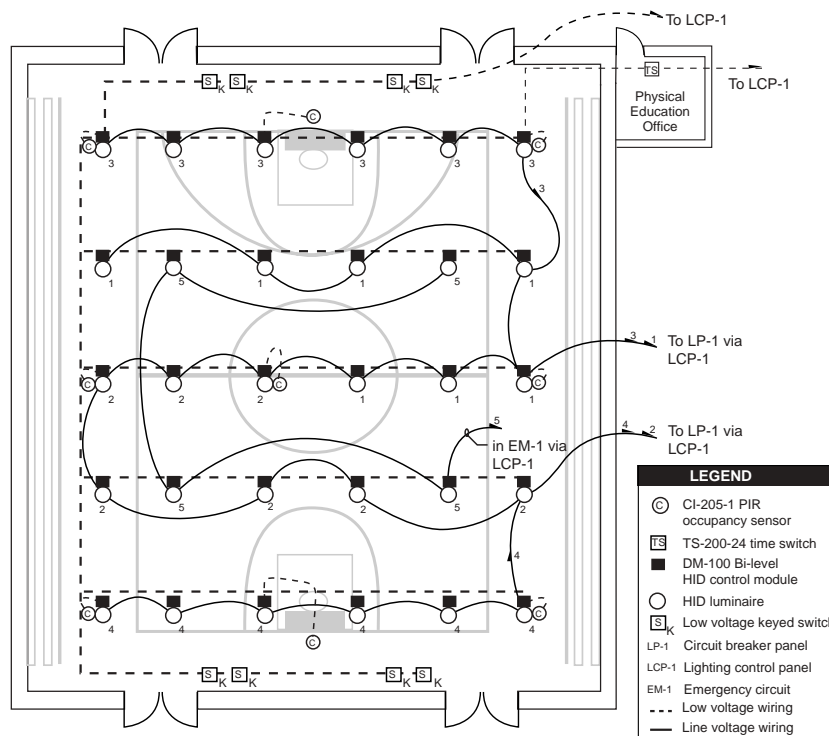

DM-100 Bi-level HID Controller Installation with Integral Ballast

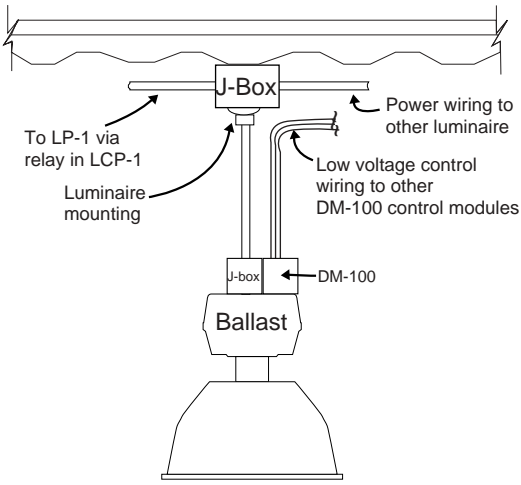

DM-100 Bi-level HID Controller Installation with Remote Ballast

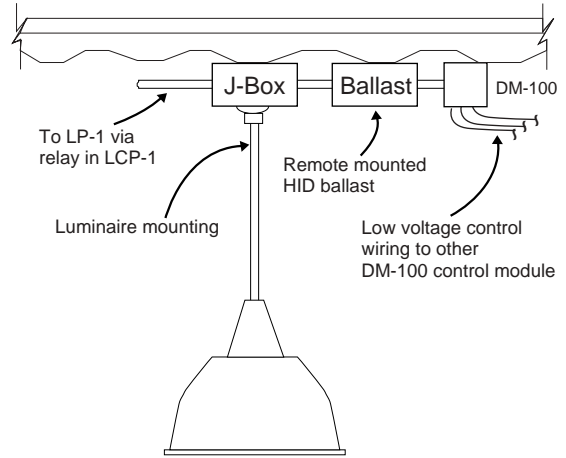

Typical CWA Ballast Wiring

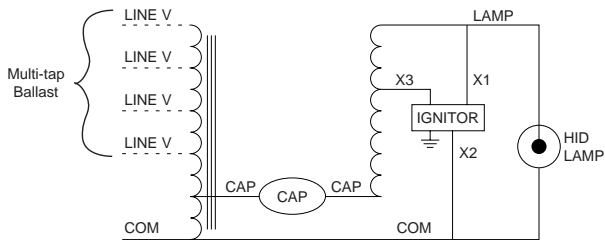

Typical CWA Ballast Wiring using DM-100

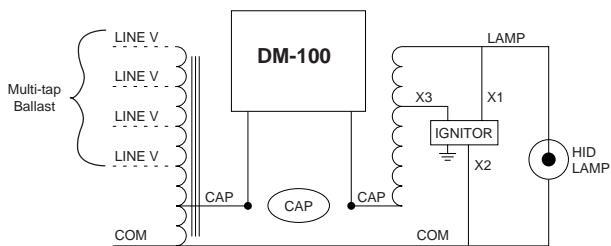

Drawings show typical wiring for Pulse Start and HPS lamps

CI-205-1 Luminaire Installation

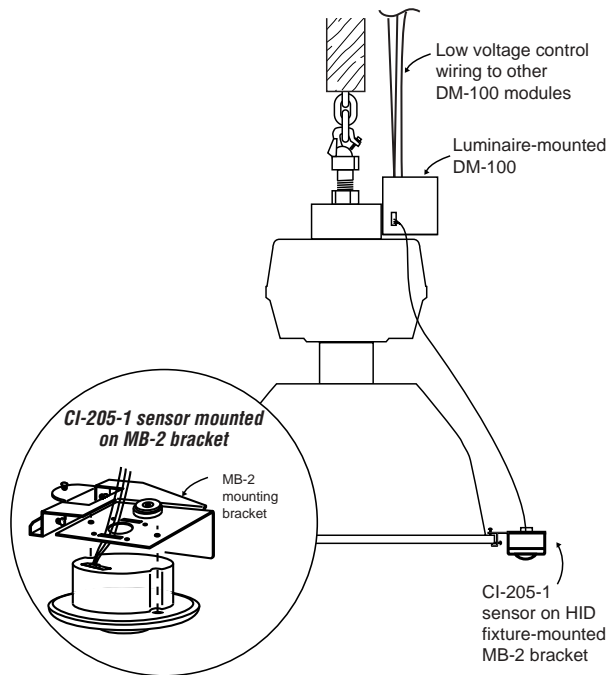

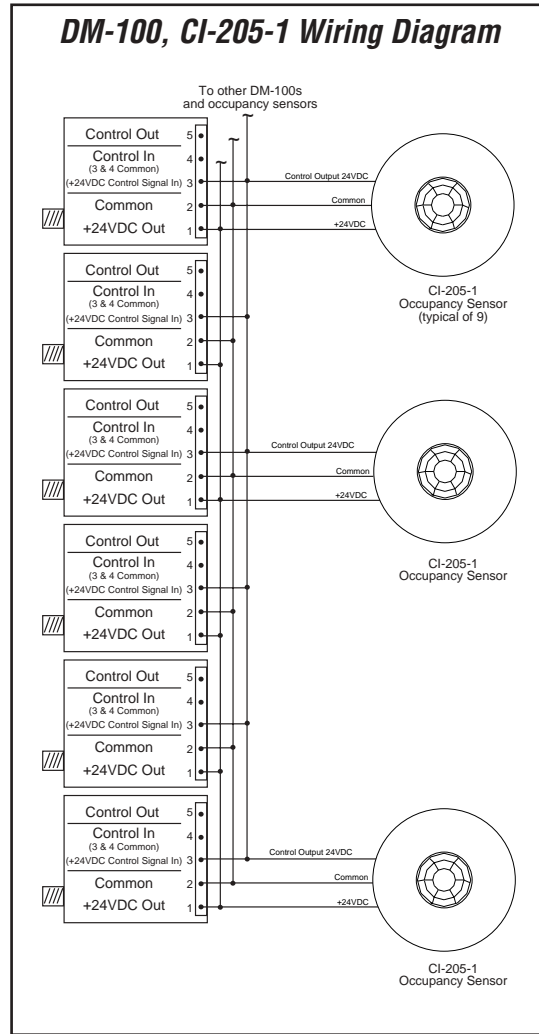
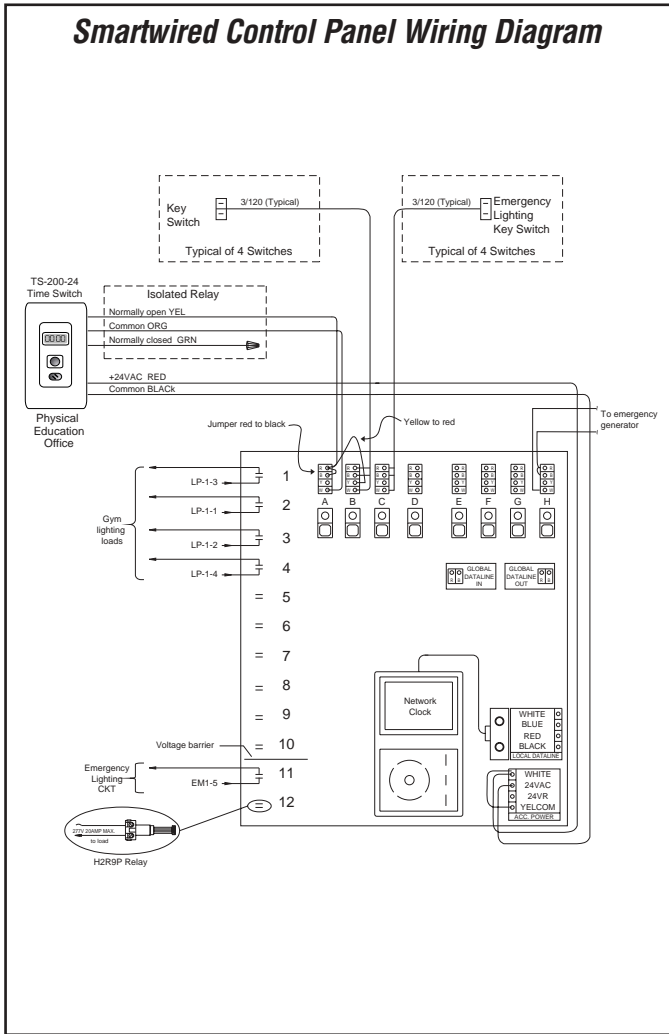

Panel Documentation

SMARTWIRED SWITCHING SYSTEM NETWORK CLOCK AUTOMATION

CHANNEL	DESCRIPTION OF GROUP	AUTOMATION SCENARIO	DATA
A	Gymnasium lighting	<input checked="" type="checkbox"/> SCHEDULED ON/OFF	ON: 7 am. OFF: 4 pm. M-F
		<input type="checkbox"/> MANUAL ON/SCHEDULED OFF	No blink warn
		<input type="checkbox"/> MANUAL ON/SWEEP AUTO SW	
		<input type="checkbox"/> ASTRO (DARK) ON/OFF	
B	Gymnasium lighting	<input checked="" type="checkbox"/> SCHEDULED ON/OFF	ON: 7 am. OFF: 4 pm. M-F
		<input type="checkbox"/> MANUAL ON/SCHEDULED OFF	No blink warn
		<input type="checkbox"/> MANUAL ON/SWEEP AUTO SW	Timed override 240 min.
		<input type="checkbox"/> ASTRO (DARK) ON/OFF	

Scenario
Scheduled ON/OFF

Data Required
• ON/OFF times for each day of the week and holidays
• Blink warn (YES/NO)

SMARTWIRED SWITCHING SYSTEM RELAY SCHEDULE

PANEL NUMBER: LRP-1

Note: Check those relays which are controlled by each automation channel under that channel letter below. (Each relay can only be associated with one channel.)

RELAY NUMBER	BRANCH CIRCUIT #	LOAD DESCRIPTION	AUTOMATION CHANNEL								
			A	B	C	D	E	F	G	H	
-01	LP-1-3	Gymnasium lights - north	X	X							
-02	LP-1-1	Gymnasium lights - north center	X	X							
-03	LP-1-2	Gymnasium lights - south center	X	X							
-04	LP-1-4	Gymnasium lights - south	X	X							
-05											
-06											
-07											
-08											
-09											
-10											
-11	EM-1-5	Night Lights			X						X
-13											
-14											
-15											
-16											
-17											
-18											
-19											

G1.1 Installation Notes

1. Refer to Smartwired Switching System Installation and Operation Summary for detailed installation and operation instructions of the lighting control panel.
2. Commission the time clock according to the Network Clock Automation Scenarios documentation, and test the operation after commissioning.
3. Assign relays to the channels as shown on the Smartwired Relay schedule.
4. Test the operation of lighting control panels, key switches and time switches after installation.
5. Adjust the TS-200-24 time switch DIP settings for time delay period, time scrolling, flash and beeper options before installing the switch. Factory set time delay is 3 hours. The maximum time delay setting should provide enough time for evening events and after school activities that occur after scheduled OFF time. Set the time switch flash option of OFF (DIP switch 5) for HID lighting installations. Time scrolling is factory preset for scrolling up which means that the time-out setting will increase while the button is held down. Refer to installation instructions for additional details.
6. Coordinate CI-205 occupancy sensor and luminaire mounting heights. Mount sensor at the same height as luminaire so that sensor view is not blocked. Use MB-2 mounting bracket for mounting CI-205 sensor to luminaire.
7. CI-205 sensor is shipped with a factory preset time delay of 18 minutes and sensitivity set to maximum. Set the time delay at 30 minutes for middle and high school gymnasiums. Refer to installation instructions for adjustment instructions.
8. Use a minimum of 22 gauge wire for low voltage wiring. See Technical Bulletin TB-124 on Voltage Loss at www.wattstopper.com.
9. Wire channels A and B in parallel so that the loads connected to each channel are controlled by the longest time delay set by either the time switch or low voltage key switch activation.
10. Power the Smartwired control panel from the emergency circuit panel.
11. Use a dedicated relay channel for the control input from the generator to assure that the emergency lighting remains ON when the generator is activated.
12. Confirm night light/egress lighting requirement with local code officials.

Equipment Schedule

Catalog No.	Qty	Description
HIN12R12SP	1	Smartwired Control lighting control panel interior, 12 relays
HTUB12	1	Tub enclosure for lighting control panel, up to 12 relays, 16"x16.5"x4.5"
HCVR12SL	1	Surface mounted cover for lighting control panel, up to 12 relays, 16.28"x16.7"x.75"
HCLK8SS	1	Network clock/programmer for Smartwired Control lighting control panel
HPSM115/277	1	Power supply for lighting control panel, 115/277 VAC, 50/60 Hz
TS-200-24	1	Digital time switch, low voltage, with ASP-211 single gang cover plate
LVS-1K	8	Low voltage key switch, single-pole, double-throw momentary operation (key supplied with switch)
SL2	4	Wall plate, Pass & Seymour/legrand, type 430, stainless steel finish, two-gang
DM-100-350MP	30	Bi-level HID control module, for 350-watt pulse start lamp operated by a CWA ballast
CI-205-1	9	Passive infrared occupancy sensor, high density/reduced range lens
MB-2	7	Mounting bracket for mounting sensor to HID luminaire

G2.0 Partitioned Gymnasium: time scheduling

Control Needs	Solution	Application Description
Scheduled, automatic OFF	Time clock in Smartwired lighting control panel	Space use: Physical education classes, with basketball and volleyball some evenings; space is locked during the day
Operate each gym individually and together; half court lighting	Time clock in Smartwired lighting control panel and dataline switch	Dimensions: 110' x 185'
Manual ON/OFF control	Master dataline switch	Ceiling height: 28'
Local manual ON/OFF of a portion of space for cleaning	Low voltage keyed switches	Windows: None
		Window blinds: None
		Skylights: None
		Lighting
		Pendant mounted prismatic low-bay metal halide luminaires using 400 watt lamps

Design Considerations

The gymnasium lighting is scheduled off after school hours using a Smartwired lighting control panel with a time clock. Two groups of luminaires in each gym are automatically turned off 30 minutes apart to allow for an override if needed. An 8-button Dataline Switch located in the PE teacher's office provides manual on control of each gym independently or together. Low voltage keyed switches at entrances allow manual on overrides of two groups of lighting for cleaning or maintenance. The time clock in the panel provides the automatic shut off of this override after 4 hours.

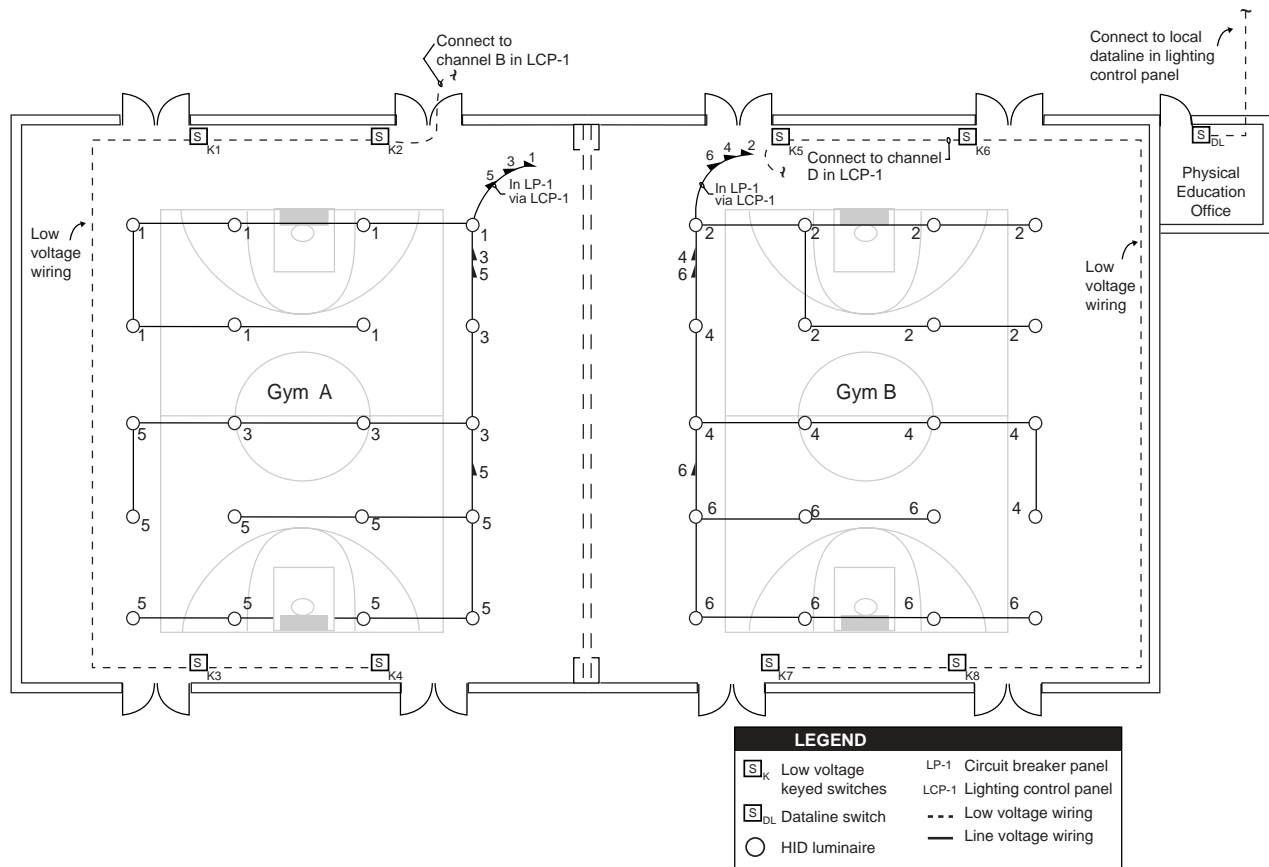

Smartwired Control Lighting Control Panel Wiring Diagram

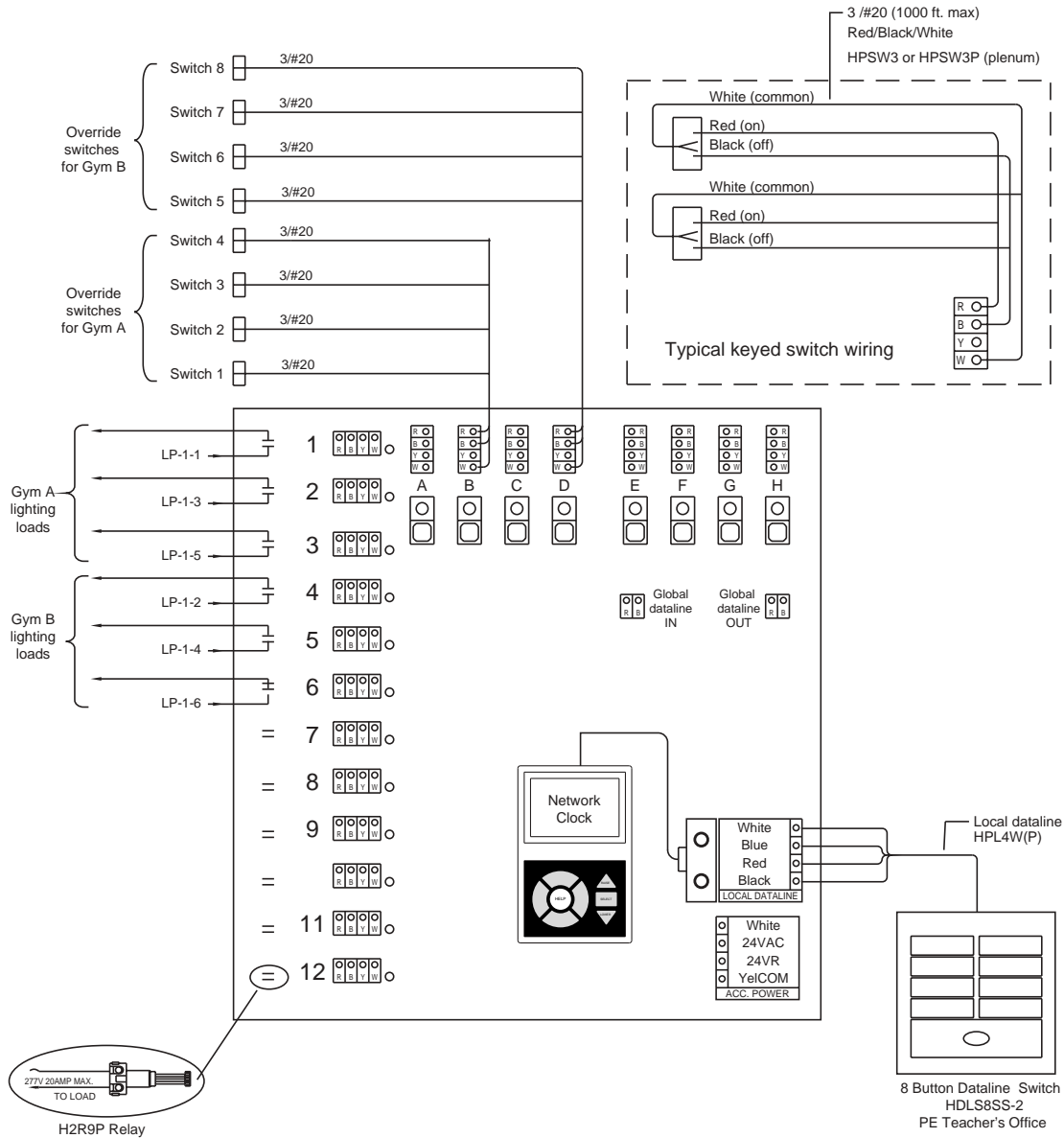

Panel Documentation

SMARTWIRED SWITCHING SYSTEM RELAY SCHEDULE PANEL NUMBER LCP-1

Note: Check those relays which are controlled by each automation channel under that channel letter below. (Each relay can only be associated with one channel.)

RELAY NUMBER	CIRCUIT #	LOAD DESCRIPTION	AUTOMATION CHANNEL							
			A	B	C	D	E	F	G	H
-01	LP-1-1	Gymnasium A - North		X						
-02	LP-1-3	Gymnasium A - Center	X							
-03	LP-1-5	Gymnasium A - South		X						
-04	LP-1-2	Gymnasium B - North				X				
-05	LP-1-4	Gymnasium B - Center			X					
-06	LP-1-6	Gymnasium B - South				X				
-07										
-08										
-09										
-10										
-11										
-12										
-13										
-14										
-15										
-16										
-17										

SMARTWIRED SWITCHING SYSTEM DATALINE SWITCH DOCUMENTATION PANEL NUMBER LCP-1

Note: Use this form for Dataline Switches and/or Universal Switch Modules connected to the local Dataline of the panel number indicated above.

SWITCH DESIGNATION	BUTTON# (8 MAX) ¹	RELAYS ² CONTROLLED PANEL # - RELAYS ²	DESCRIPTION	SPECIAL FUNCTION
1	1	LCP-1 -R1-R3	Gymnasium A - All	
1	2	LCP-1 - R1, R2	Gymnasium A - North	
1	3	LCP-1 -R2, R3	Gymnasium A - South	
1	4	LCP-1 -R4-R6	Gymnasium B - All	
1	5	LCP-1 -R4, R5	Gymnasium B - North	
1	6	LCP-1 -R5, R6	Gymnasium B - South	
1	7	LCP-1 R1-R6	Gymnasiums A & B - All	
1	8	LCP-1 -R1, R3, R4, R6	Gym A & B - Perim	

SMARTWIRED SWITCHING SYSTEM NETWORK CLOCK AUTOMATION

CHANNEL	DESCRIPTION OF GROUP	AUTOMATION SCENARIO	DATA
A	Gymnasium A - Center	<input type="checkbox"/> SCHEDULED ON/OFF	Off at 5pm M-F
		<input checked="" type="checkbox"/> MANUAL ON/SCHEDULED OFF	No blink warn
		<input type="checkbox"/> MANUAL ON/SWEEP AUTO SW	240 minute timed override
		<input type="checkbox"/> ASTRO (DARK) ON/OFF	
		<input type="checkbox"/> ASTRO (DARK) ON/SCHED OFF	
B	Gymnasium A - North & South	<input type="checkbox"/> SCHEDULED ON/OFF	Off at 5:30 pm M-F
		<input checked="" type="checkbox"/> MANUAL ON/SCHEDULED OFF	No blink warn
		<input type="checkbox"/> MANUAL ON/SWEEP AUTO SW	240 minute timed override
		<input type="checkbox"/> ASTRO (DARK) ON/OFF	
		<input type="checkbox"/> ASTRO (DARK) ON/SCHED OFF	
C	Gymnasium B - Center	<input type="checkbox"/> SCHEDULED ON/OFF	Off at 5 pm M-F
		<input checked="" type="checkbox"/> MANUAL ON/SCHEDULED OFF	No blink warn
		<input type="checkbox"/> MANUAL ON/SWEEP AUTO SW	240 minute timed override
		<input type="checkbox"/> ASTRO (DARK) ON/OFF	
		<input type="checkbox"/> ASTRO (DARK) ON/SCHED OFF	
D	Gymnasium B - North & South	<input type="checkbox"/> SCHEDULED ON/OFF	Off at 5:30 pm M-F
		<input checked="" type="checkbox"/> MANUAL ON/SCHEDULED OFF	No blink warn
		<input type="checkbox"/> MANUAL ON/SWEEP AUTO SW	240 minute timed override
		<input type="checkbox"/> ASTRO (DARK) ON/OFF	
		<input type="checkbox"/> ASTRO (DARK) ON/SCHED OFF	

G2.0 Installation Notes

1. Refer to Smartwired Switching System Installation and Operation Summary for detailed installation and operation instructions of the lighting control panel.
2. Dataline wire must conform with The Watt Stopper specifications. Use dataline wire for wiring between dataline switches and Smartwired panels.
3. Use a minimum of 22 gauge wire for low voltage key switch wiring. See Technical Bulletin TB-124 on Voltage Loss at www.wattstopper.com.
4. Test the operation of lighting control panels, dataline wire, and dataline switches after installation.
5. Commission the time clock according to the Network Clock Automation Scenarios documentation, and test the operation after commissioning.
6. Assign relays to the channels as shown on the Smartwired Relay Schedule.
7. Configure the Dataline Switch buttons as shown on the Dataline Switch Documentation.
8. Use stainless steel switch plates to facilitate cleaning and minimize damage from impact.

Equipment Schedule

<i>Catalog No.</i>	<i>Qty</i>	<i>Description</i>
HIN12R12SP	1	Smartwired Control lighting control panel interior, 12 relays
HTUB12	1	Tub enclosure for lighting control panel, up to 12 relays, 16"x16.5"x4.5"
HCVR12SL	1	Surface mounted cover for lighting control panel, up to 12 relays, 16.28"x16.7"x.75"
HCLK8SS	1	Network clock/programmer for Smartwired Control lighting control panel
HPSM115/277	1	Power supply for lighting control panel, 115/277 VAC, 50/60 Hz
HDLS8SS	1	Dataline Switch, octal, 8 individual buttons plus master, double-gang, includes plate
LVS-1K	8	Low voltage key switch, single-pole, double-throw momentary operation (key supplied with switch)
SL1	8	Wall plate, Pass & Seymour/legrand, type 430, stainless steel finish, single gang
HDLW4		Dataline wire, 18 AWG (7 strands x 26 AWG) using 2 independent twisted pair (specify feet)

H1.0 Hallway, Vestibule, Lobby: time scheduling • occupancy sensing

Control Needs	Solution	Application Description
Schedule ON at 7 AM	Time clock in Smartwired lighting control panel	Space use: General circulation, entrance/exit, emergency exit path
Occupancy-based control of outboard lamps in hallway and all lamps in lobby and vestibule during after hours (4 PM)	Occupancy sensors (WT and CI series)	Dimensions: Hallway: 90' x 8' Lobby: 22' x 9' Vestibule: 11' x 14'
Night lights on all of the time	Night lights are not controlled	Ceiling height: 10' Windows: In vestibule Window blinds: None Skylights: None
Night lights operate during power outage	Power night lights through emergency panel	
		Lighting
		Recessed 3-lamp 1x4 with tandem wired 2-lamp electronic ballasts in hallway. Compact fluorescent downlights in hallway, lobby and vestibule

Design Considerations

Lighting in the hallway, lobby, and vestibule is scheduled on in the morning using a time clock located in a Smartwired lighting control panel and reverts to occupancy sensor control after school hours, beginning at 4 PM. All lights remain on during normal operating hours. For after school hours, a WT-2255 ultrasonic occupancy sensor controls lobby downlights and hallway outboard lamps, and a CI-205 passive infrared sensor controls vestibule downlights. The sensors keep controlled lamps on when the spaces are occupied and off when no one is present. The center lamps in two of the hallway fixtures are used as night lighting. These are not controlled and remain on at all times.

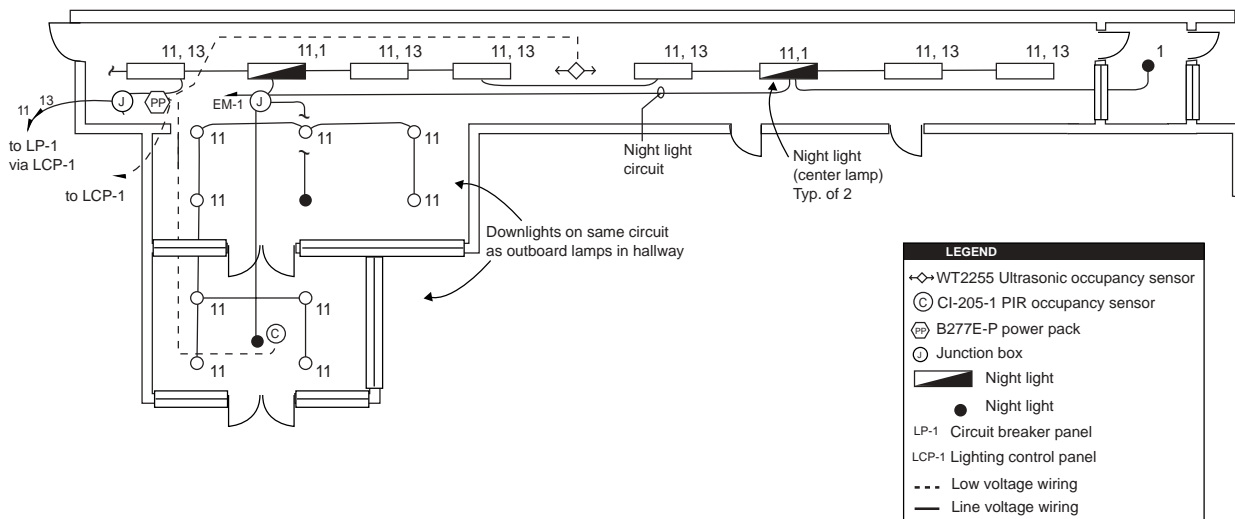

WT-2255 Ultrasonic Sensor Installation

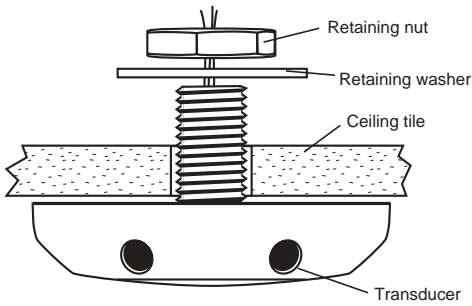

Power pack

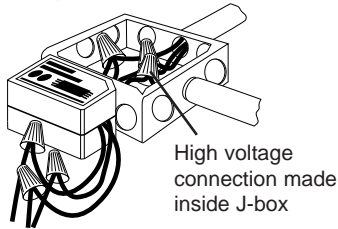

CI-205-1 Occupancy Sensor Installation

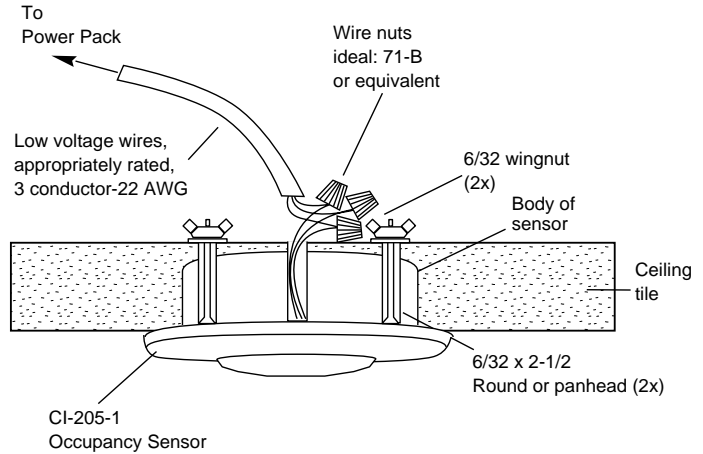

Panel Documentation

SMARTWIRED SWITCHING SYSTEM RELAY SCHEDULE

PANEL NUMBER

Note: Check those relays which are controlled by each automation channel under that channel letter below. (Each relay can only be associated with one channel.)

RELAY NUMBER	CIRCUIT	LOAD DESCRIPTION	AUTOMATION CHANNEL										
			A	B	C	D	E	F	G	H			
-01	PP	Override Vestibule, Lobby, Hallway Outboard	X										
-02		Spare											
-03	LP-1-13	Hallway Center Lamps	X										
-04													
-05													
-06													
-07													
-08													

SMARTWIRED SWITCHING SYSTEM NETWORK CLOCK AUTOMATION

CHANNEL	DESCRIPTION OF GROUP	AUTOMATION SCENARIO	DATA
A	Vestibule, lobby and hallway	<input checked="" type="checkbox"/> SCHEDULED ON/OFF	On 7 am; Off 4 pm
		<input type="checkbox"/> MANUAL ON/SCHEDULED OFF	
		<input type="checkbox"/> MANUAL ON/SWEEP AUTO SW	
		<input type="checkbox"/> ASTRO (DARK) ON/OFF	
		<input type="checkbox"/> ASTRO (DARK) ON/SCHED OFF	
B		<input type="checkbox"/> SCHEDULED ON/LOW	
		<input type="checkbox"/> MANUAL ON/SCHEDULED OFF	
		<input type="checkbox"/> MANUAL ON/SWEEP AUTO SW	
		<input type="checkbox"/> ASTRO (DARK) ON/OFF	
		<input type="checkbox"/> ASTRO (DARK) ON/SCHED OFF	

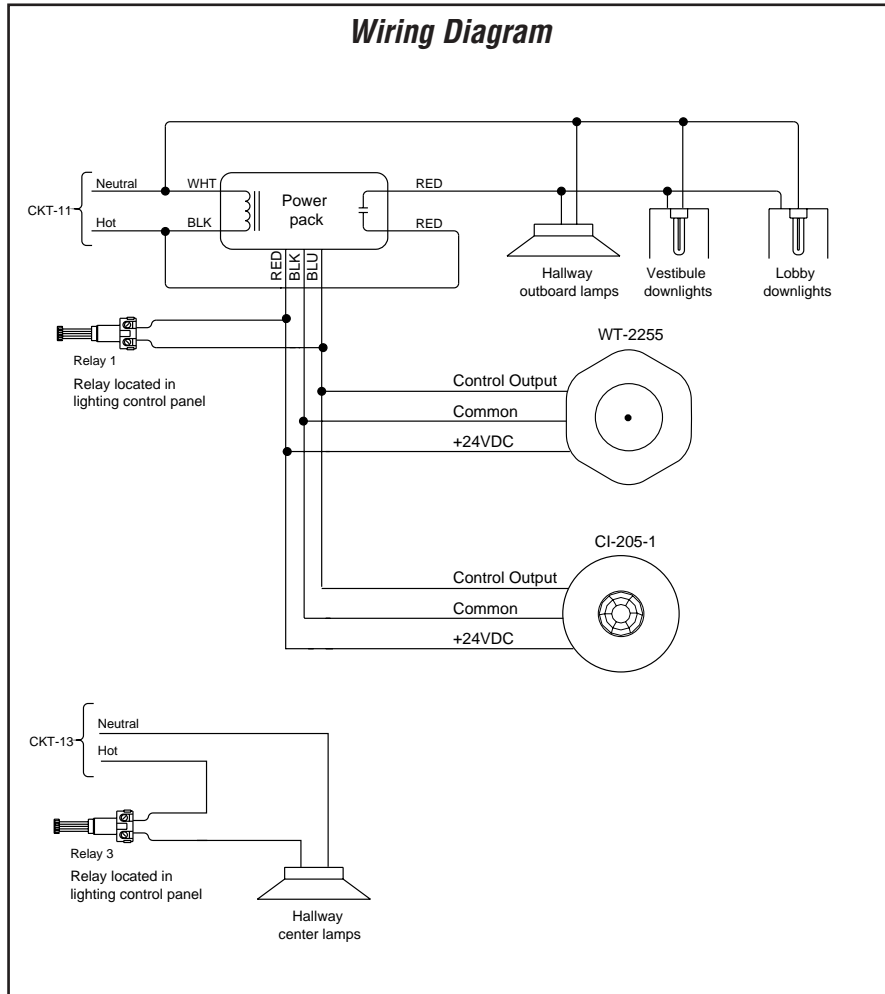

H1.0 Installation Notes

1. Orient WT-2255 occupancy sensor in center of hallway to obtain coverage of entire hallway and into lobby. Point transducers towards the ends of the hallway.
2. Orient CI-205-1 occupancy sensor in center of vestibule.
3. WT-2255 sensor is shipped with a factory preset time delay of 16 minutes, CI-205-1 is preset at 18 minutes. The WT-2255 is shipped with sensitivity setting at 50%, the CI-205-1 at maximum. Refer to installation instructions if adjustments are necessary.
4. Mount the WT-2255 sensor on a rigid, vibration-free surface, at least six inches from the power pack, four feet from supply air ducts and six feet from horizontal discharge ducts.
6. Use a minimum of 22 gauge wire for low voltage wiring. See Technical Bulletin TB-124 on Voltage Loss at www.wattstopper.com.
7. Refer to Smartwired Switching System Installation and Operation Summary for detailed installation and operation instructions of the lighting control panel.
8. Commission the time clock according to the Network Clock Automation Scenarios documentation, and test the operation after commissioning.
9. Assign relays to the channels as shown on the Smartwired Relay schedule.
10. Confirm night light/egress lighting requirement with local code officials.

Equipment Schedule

Catalog No.	Qty	Description
WT-2255	1	Ultrasonic occupancy sensor, 90 linear ft, for hallway use
CI-205-1	1	Passive infrared occupancy sensor, high density lens, 360° coverage
B277E-P	1	277 VAC, 60Hz power pack
HIN8R12SP	1	Smartwired Control lighting control panel interior, 8 relays
HTUB12	1	Tub enclosure for lighting control panel, up to 12 relays, 16"x16.5"x4.5"
HCVR12SL	1	Surface mounted cover for lighting control panel, up to 12 relays, 16.28"x16.7"x.75"
HCLK8SS	1	Network clock/programmer for Smartwired Control lighting control panel
HPSM115/277	1	Power supply for lighting control panel, 115/277 VAC, 50/60 Hz

M1.0 Multipurpose Room: occupancy sensing • bi-level switching

Control Needs	Solution	Application Description
Automatically turn lights ON/OFF based on occupancy	Corner-mounted, dual technology occupancy sensor (DT series)	<p>Space use: Daytime use for physical education classes, general assembly, and cafeteria/lunch room activities. Evening use for plays and school events. Space is locked during unoccupied times.</p> <p>Dimensions: 60' x 65'</p> <p>Ceiling height: 15'</p> <p>Windows: None</p> <p>Window blinds: None</p> <p>Skylights: None</p>
Bi-level switching	Separate circuits for center and outboard ballasts and wall switches	
Manual override OFF	Wall switches	
Occupancy-based control of HVAC system	Isolated relay on occupancy sensor	
		<p>Lighting</p> <p>Recessed fluorescent lensed luminaires using four F32 T8 lamps and 2-lamp electronic ballasts. Ballasts controlling center lamps are circuited separately from ballasts controlling outboard lamps.</p>

Design Considerations

DT-200 dual technology occupancy sensors are used to automatically turn lights off when the multi-purpose room is unoccupied, and turn lights on upon occupancy. Each sensor is corner-mounted to prevent a view out the doorway that might otherwise result in false activations. For manually overriding lights off and for bi-level lighting control, wall switches are placed at each door which independently control the center lamps from the outboard lamps.

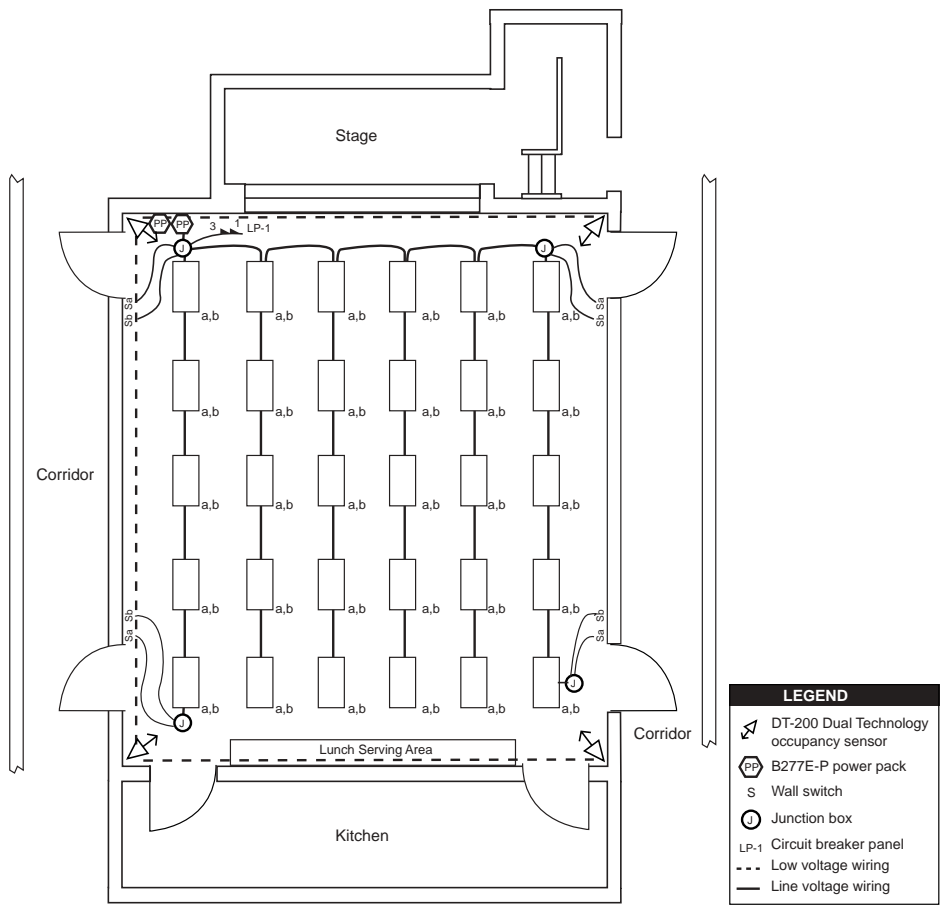

M1.0 Installation Notes

1. Mount DT-200 occupancy sensors 10 feet above finish floor.
2. Mount DT-200s in corners and aim at opposing corner to provide a full view of the room.
3. DT-200 is shipped with a factory preset time delay of 18 minutes, the recommended minimum for multi-purpose rooms, and with sensitivity setting at maximum. Refer to installation instructions if adjustments are necessary.
4. Use a minimum of 22 gauge wire of low voltage wiring. For more information, read our Tech Bulletin TB124 on voltage loss.
5. Use stainless steel switch plates to facilitate cleaning and minimize damage from impact.
6. DT-200 sensor isolated relay can provide status information to the BAS and/or control HVAC loads.

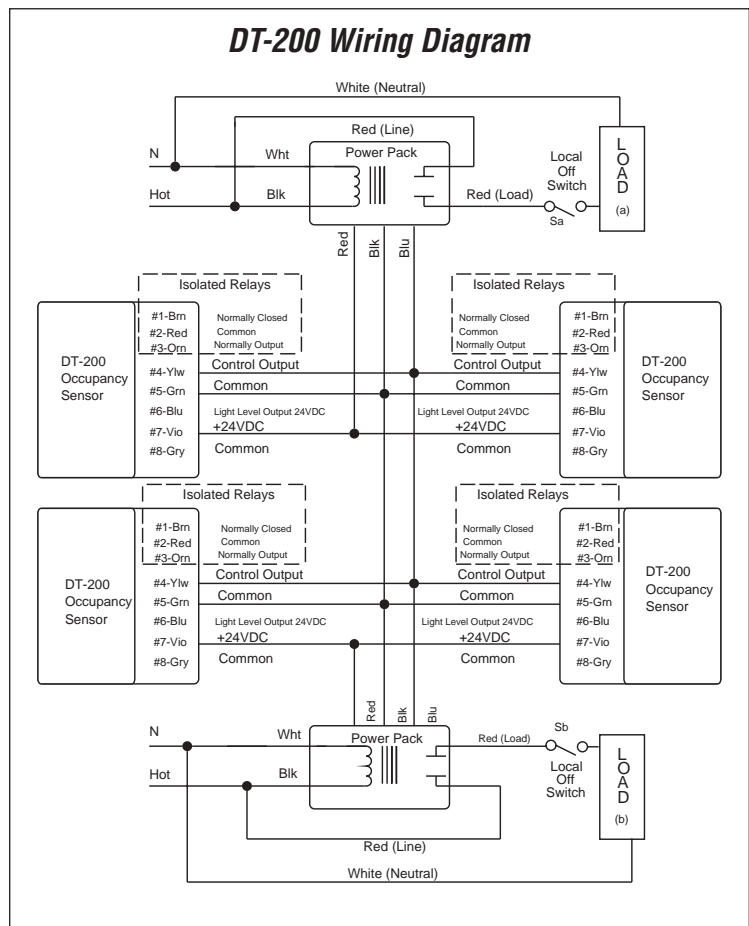
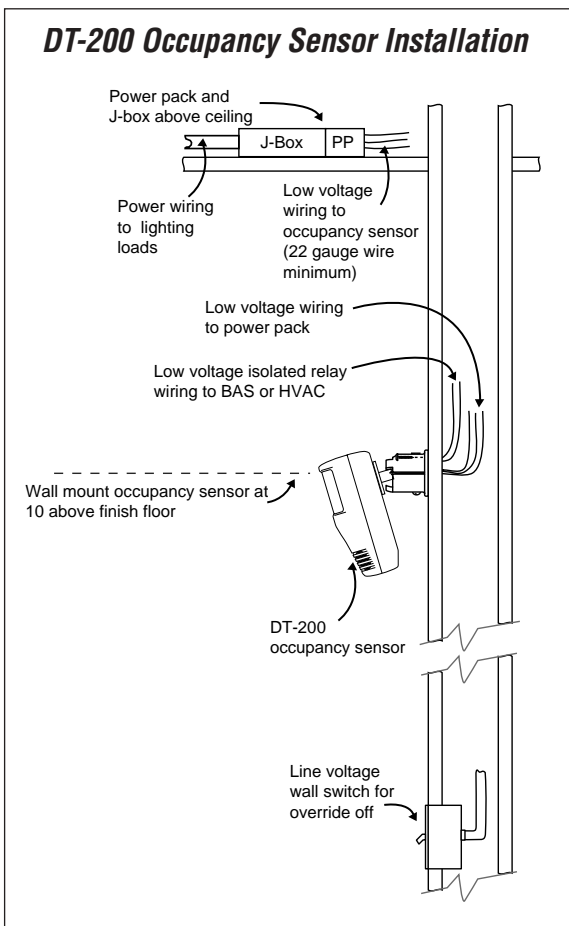

Equipment Schedule

Catalog No.	Qty	Description
DT-200	4	Dual technology occupancy sensor, isolated relay, wide angle lens
B277E-P	2	Power pack, 277 VAC, 60 Hz
AC1 Series	8	Wall switch, Pass & Seymour/legrand, AC1 series, single pole
SL2	4	Wall plate, Pass & Seymour/legrand, type 430, stainless steel finish, double-gang

R1.0 Large Restroom: occupancy sensing

Control Needs	Solution	Application Description
Automatically turn lights ON/OFF based on occupancy	Ceiling mounted ultrasonic occupancy sensor (WT-1105)	Space use: Restroom Dimensions: 12' x 20' Ceiling height: 10'
Manual override lighting and fan OFF	Keyed wall switches	Windows: None Window blinds: None Skylights: None
Control 120 volt exhaust fan together with lighting	Slave pack for controlling fan using occupancy sensor	
Night lights on all the time	Night lights not controlled	

Lighting

Recessed 1 x 4 luminaires using two T8 lamps and a 277 volt 2-lamp electronic ballast

Design Considerations

A WT-1105 ultrasonic occupancy sensor is ceiling-mounted in the center of each restroom, turning lighting on when the space is occupied and off when vacant. The choice of ultrasonic sensor was made because it can detect occupancy around stall partitions and other obstacles. The sensor is powered by a power pack that is located next to the junction box. A slave pack is used for controlling the exhaust fan with the same occupancy sensor. This is necessary since the fan is a different voltage than the lighting load. Keyed switches allow the lights to be overridden off when necessary. Night lighting is not controlled and remains on at all times.

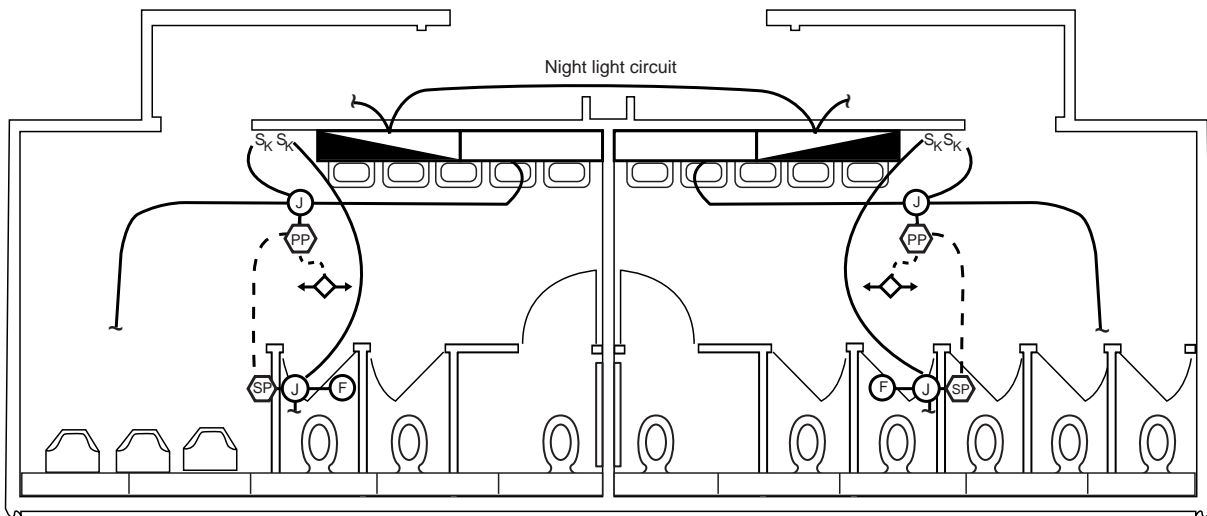

LEGEND	
	WT-1105 Ultrasonic occupancy sensor
	B277E-P power pack
S_K	Keyed wall switch
	S120/277/347-P slave pack
	120 volt exhaust fan
	Junction box
	Night light fixture
- - -	Low voltage wiring
—	Line voltage wiring

R1.0 Installation Notes

1. Mount power and slave packs next to junction box above acoustical tile ceiling. This minimizes wiring and simplifies installation. For drywall ceilings, mount power and slave packs above access panel.
2. Orient WT-1105 in center of the room to have view of entire space and over stalls.
3. Mount the WT-1105 sensor on a rigid, vibration-free surface, at least six inches from the power pack, four feet from supply air ducts and six feet from horizontal discharge ducts.
4. WT-1105 sensor is shipped with a factory preset time delay of 16 minutes and sensitivity set to 50%, both recommended for restrooms. Refer to installation instructions if adjustments are necessary.
5. Use a minimum of 22 gauge wire for low voltage wiring. See Technical Bulletin TB-124 on Voltage Loss at www.wattstopper.com.
6. Confirm night light/egress lighting requirement with local code officials.
7. Use stainless steel wall switch plates to facilitate cleaning and minimize damage from impact.

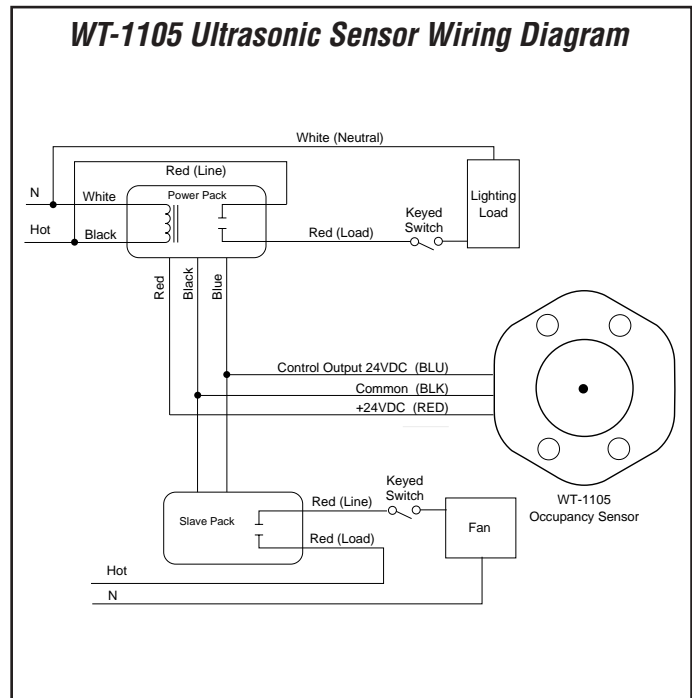
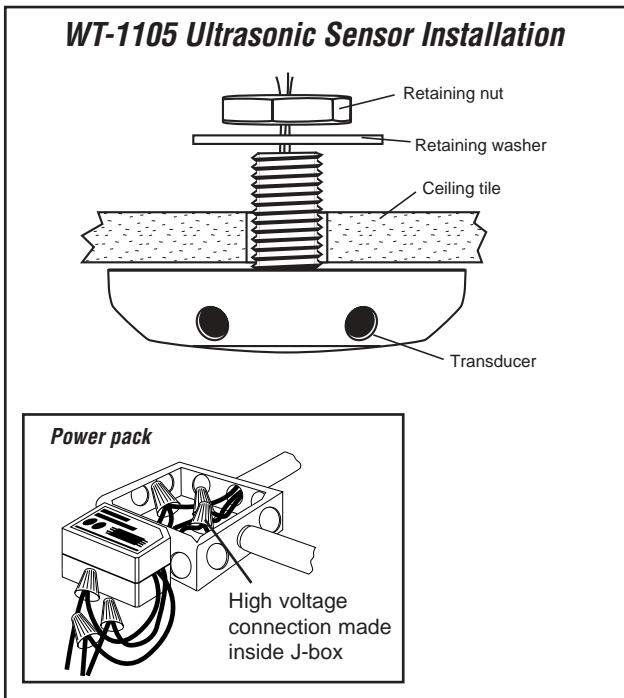

Equipment Schedule (per restroom)

Catalog No.	Qty	Description
WT-1105	1	Ultrasonic occupancy sensor, 1000 sq ft, 360° coverage
B277E-P	1	Power pack, 277 VAC, 60 Hz
S120/277/347E-P	1	Slave pack, 120/277/347 VAC
AC1-L	2	Keyed wall switch, Pass & Seymour/legrand, single-pole
SL2	1	Wall plate, Pass & Seymour/legrand, type 430 stainless steel finish, two-gang

R2.0 Small Restrooms: occupancy sensing

Control Needs	Solution	Application Description
Automatically turn lights ON/OFF based on occupancy	Ceiling-mounted ultrasonic occupancy sensor (WT-605)	Space use: Restroom Dimensions: 12' x 8' Ceiling height: 10'
Control 120 volt exhaust fan together with lighting	Slave pack for controlling fan using occupancy sensor	Windows: None Window blinds: None Skylights: None
Manual override lighting and fan OFF	Keyed wall switches	
		Lighting
		Recessed 1 x 4 lens luminaires using two T8 lamps and a 277 volt, 2-lamp electronic ballast

Design Considerations

A WT-605 ultrasonic occupancy sensor is ceiling-mounted in the center of each restroom turning lighting on when the space is occupied and off when vacant. The choice of ultrasonic sensor was made because it can detect occupancy around stall partitions and other obstacles. The sensor is powered by a power pack that is located next to the junction box. A slave pack is used for controlling the exhaust fan with the same occupancy sensor. This is necessary since the fan is a different voltage than the lighting load. Keyed switches allow the lights to be overridden off when necessary. Night lighting is not controlled and remains on at all times.

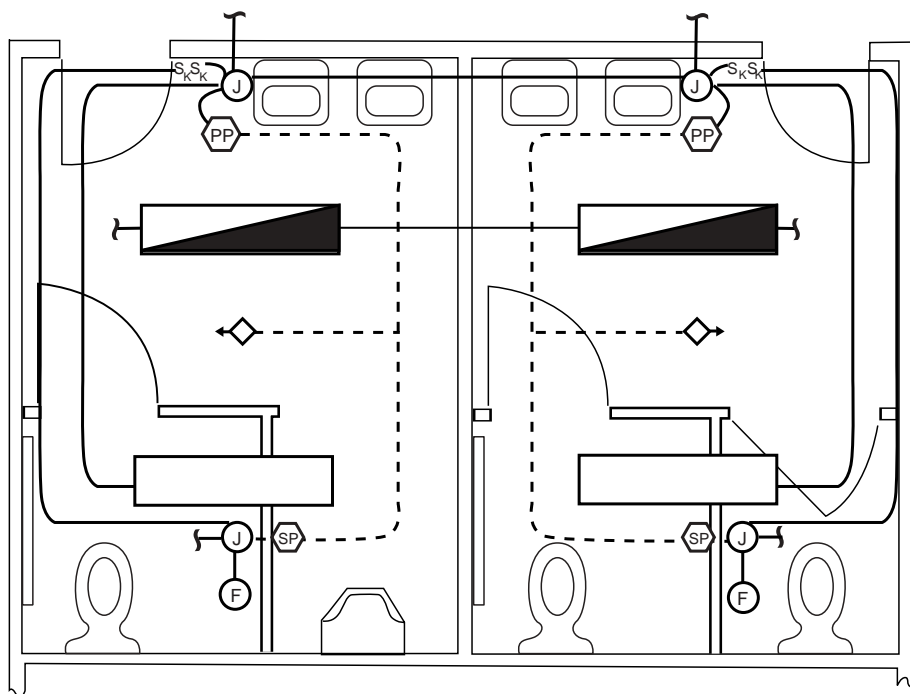

LEGEND	
	WT-605 Ultrasonic occupancy sensor
	B277E-P power pack
	Keyed wall switch
	S120/277/347-P slave pack
	120 volt exhaust fan
	Junction box
	Night light fixture
	Low voltage wiring
	Line voltage wiring

R2.0 Installation Notes

1. Mount power and slave packs next to junction box above acoustical tile ceiling. This minimizes wiring and simplifies installation. For drywall ceilings, mount power and slave packs above access panel.
2. Orient WT-605 in center of the room to have view of entire space and over stalls.
3. Mount the WT-605 sensor on a rigid, vibration-free surface, at least six inches from the power pack, four feet from supply air ducts and six feet from horizontal discharge ducts.
4. WT-605 sensor is shipped with a factory preset time delay of 16 minutes and sensitivity set to 50%, both recommended for restrooms. Refer to installation instructions if adjustments are necessary.
5. Use a minimum of 22 gauge wire for low voltage wiring. See Technical Bulletin TB-124 on Voltage Loss at www.wattstopper.com.
6. Confirm night light/egress lighting requirement with local code officials.
7. Use stainless steel wall switch plates to facilitate cleaning and minimize damage from impact.

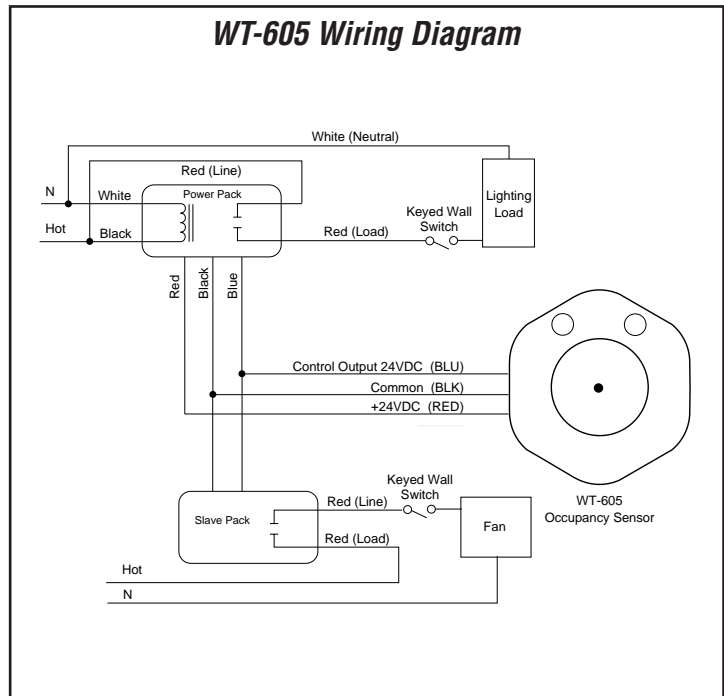
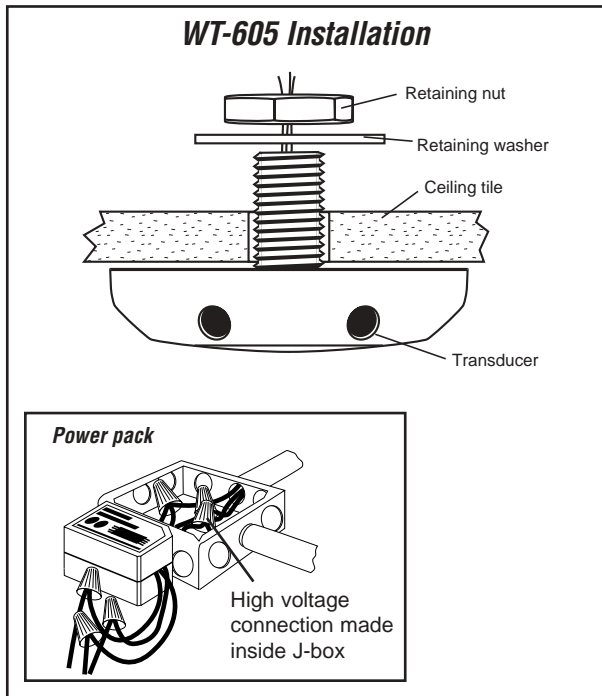

Equipment Schedule (per restroom)

Catalog No.	Qty	Description
WT-605	1	Ultrasonic occupancy sensor, 600 sq ft, 360° coverage
B277E-P	1	Power pack, 277 VAC, 60 Hz
AC1-L	2	Keyed wall switch, Pass & Seymour/legrand, single-pole
SL2	1	Wall plate, Pass & Seymour/legrand, type 430, stainless steel finish, two-gang
S120/277/347E-P	1	Slave pack, 120/277/347 VAC

R3.0 Faculty/Individual Restroom: occupancy sensing

Control Needs	Solution	Application Description
Automatically turn lights and fans ON/OFF based on occupancy	Ceiling-mounted passive infrared occupancy sensor (WPIR)	Space use: Faculty restroom Dimensions: 8' x 8' Ceiling height: 10'
Manual override lighting and fan OFF	Wall switch	Windows: None Window blinds: None Skylights: None
		Lighting
		Recessed 1 x 4 luminaires using two T8 lamps and a 120 volt, 2-lamp electronic ballast

Design Considerations

The WPIR passive infrared sensor is mounted on the ceiling, in the corner of the restroom, turning lights and the fan on when the space is occupied and off when vacant. The sensor is powered by a power pack that is located next to the junction box. In this application, the sensor choice is passive infrared because there are no stall partitions that could block the sensor's view of occupants. The wall switch provides a manual override off of the lighting and the fan.

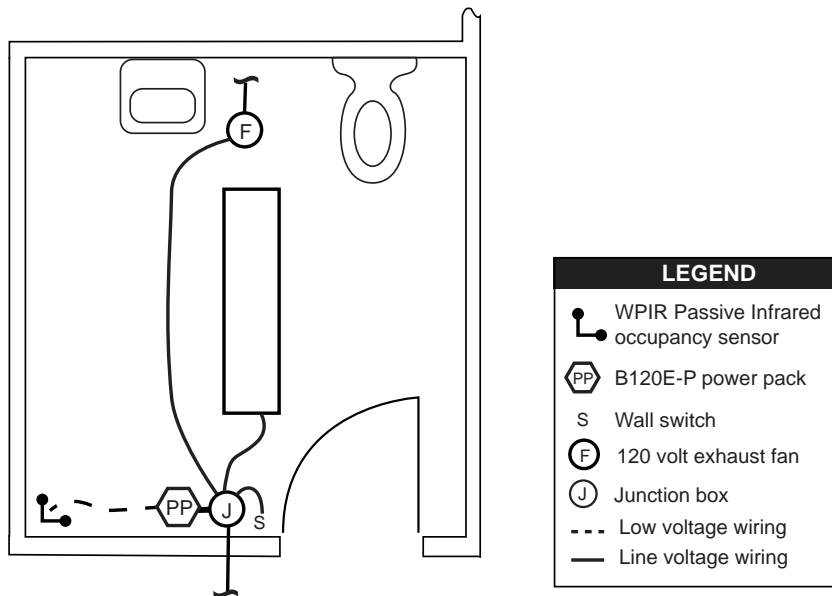

R3.0 Installation Notes

1. Mount power pack next to junction box above acoustical tile ceiling. This minimizes wiring and simplifies installation. For drywall ceilings, mount power pack above access panel.
2. Orient WPIR occupancy sensor so that it is aimed at opposing corner.
3. The WPIR may be mounted to ceiling using either the supplied threaded bracket mounting accessories, or by screw mounting as shown in the installation drawing.
4. The WPIR is shipped with a factory preset time delay of 30 minutes and sensitivity setting at maximum, which should be used for this application. Refer to installation instructions if adjustments are necessary.
5. Use a minimum of 22 gauge wire for low voltage wiring. See Technical Bulletin TB-124 on Voltage Loss at www.wattstopper.com.
6. Confirm night light/egress lighting requirement with local code officials.
7. Use stainless steel wall switch plates to facilitate cleaning and minimize damage from impact.

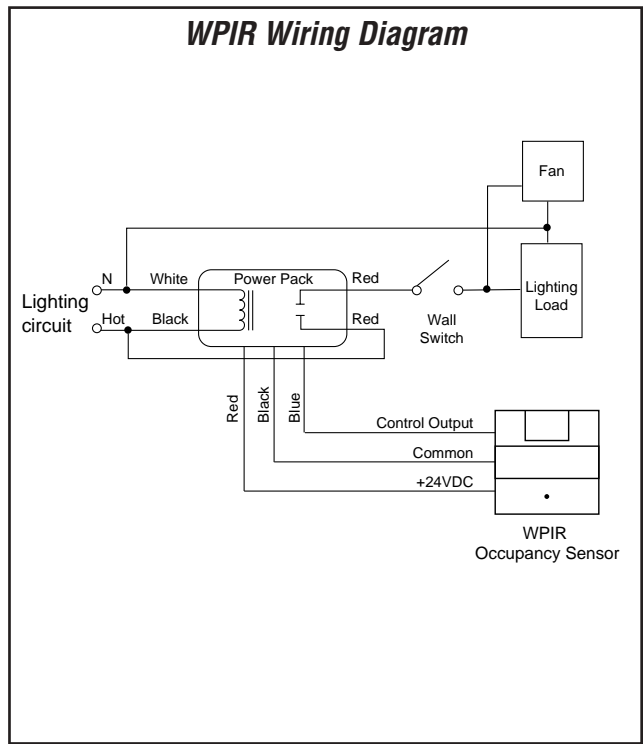
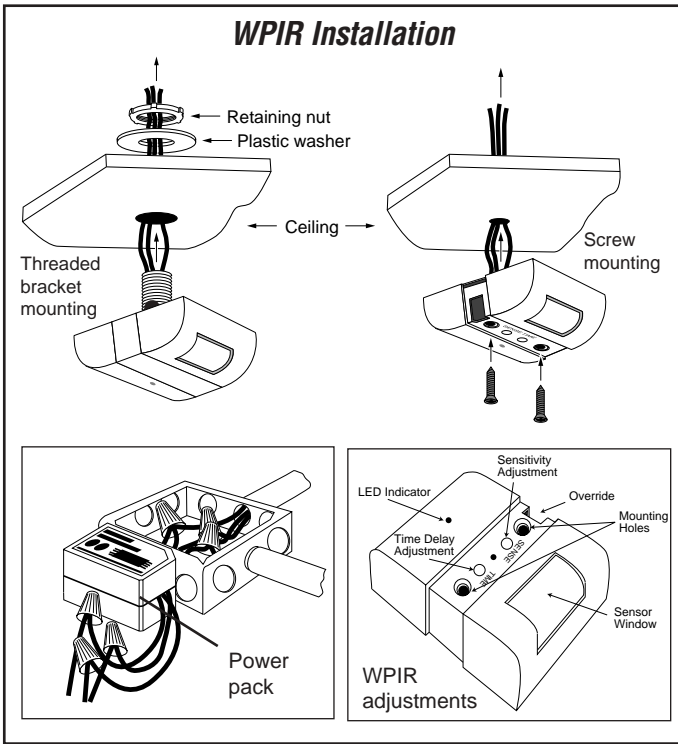

Equipment Schedule

Catalog No.	Qty	Description
WPIR	1	Passive infrared occupancy sensor
B120E-P	1	Power pack, 120 VAC, 60 Hz
AC1 series	1	Wall switch, Pass & Seymour/legrand, AC1 series, single pole
SL1	1	Wall plate, Pass & Seymour/legrand, type 430, stainless steel finish, single-gang

E1.0 Exterior Lighting: time scheduling • photocell

Control Needs	Solution	Application Description
Parking lot/walkway Turn lighting ON at dusk and OFF at 10pm leaving a portion on all night for security	Photocell ON/scheduled OFF using time clock in lighting control panel	Exterior lighting control of building, parking lot, walkway, and canopy lighting Lighting Building-mounted wallpacks for perimeter security lighting, bollards for lighting walkways, recessed downlights lighting entrances and exits, and pole-mounted "shoebox" luminaires lighting parking lots. All luminaires are operated using 277 volt power, except bollards, which are 120 volt.
Building-mounted Turn lighting ON at dusk and leave on all night for security lighting	Photocell ON/OFF controlled through lighting control panel	
Entrance/exit canopies Turn lighting ON at dusk and leave on all night for security lighting	Photocell ON/OFF controlled through lighting control panel	
Manual override for special events	Dataline switch	

Design Considerations

All the exterior and security lighting is turned on at dusk using the Smartwired lighting control panel with the Photocontrol Package and the HPSA photocell. This system allows specific on/off setpoints based on the required level of illuminance. Parking lot and walkway luminaires, not on security lighting circuits, are scheduled off at a predetermined time in the evening with the Smartwired panel's time clock. Canopy lighting turns on at 20 footcandles, walkway lighting at 10 fc, and parking lot lighting at 2 fc. All security lighting turns off at dawn. A dataline switch is located in the administration office for manual override of all exterior lighting groups.

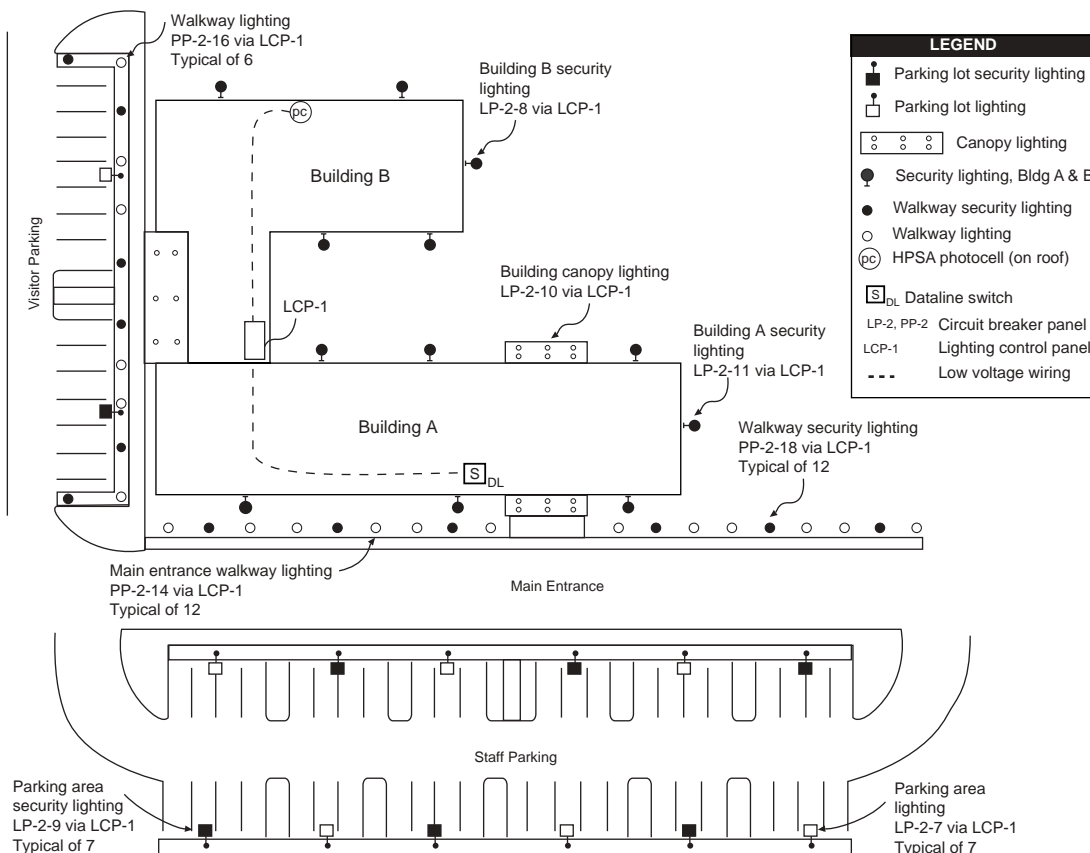

E1.0 Installation Notes

1. Refer to Smartwired Switching System Installation and Operation Summary for detailed installation and operation instructions.
2. Test the operation of lighting control panels and photocell controls after installation.
3. Commission time clock according to Network Clock Automation Scenarios documentation, test operation after commissioning.
4. Assign relays to the channels as shown on the Smartwired Relay Schedule.
5. Install the photocell on the roof facing north. Mount underside of photocell at least 12 inches above the snow line.

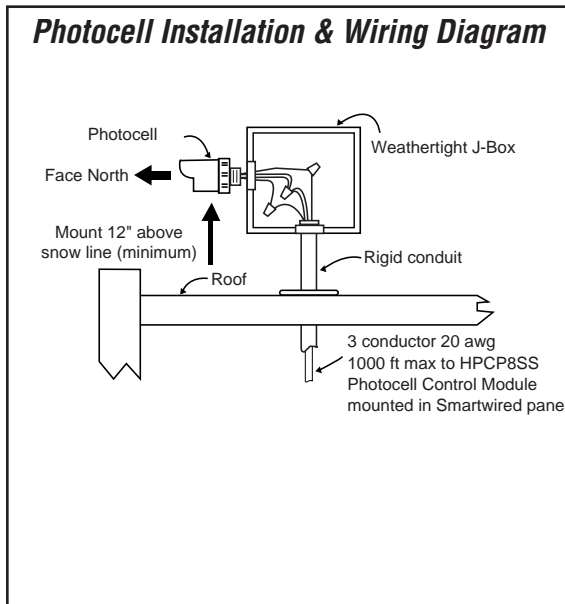
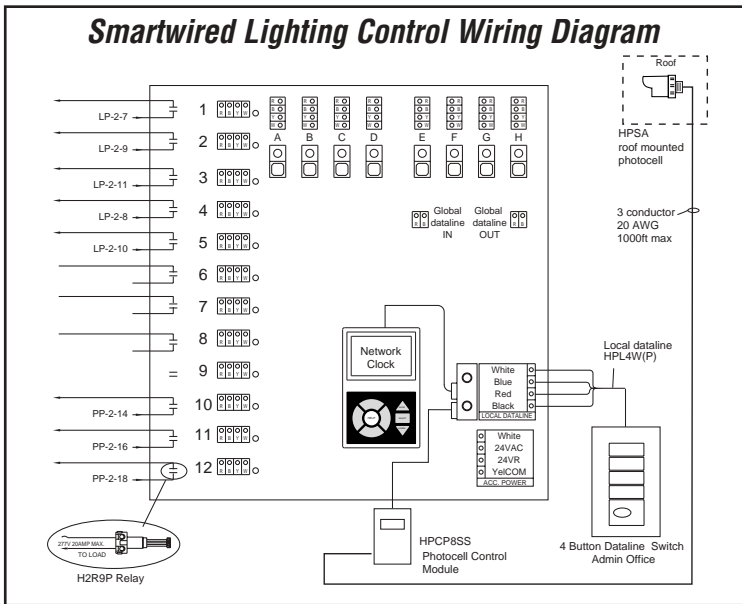

SMARTWIRED SWITCHING SYSTEM RELAY SCHEDULE					SMARTWIRED SWITCHING SYSTEM NETWORK CLOCK AUTOMATION				
RELAY NUMBER	CIRCUIT	LOAD DESCRIPTION	AUTOMATION CHANNELS					DATA	
			A	B	C	D	E		
-01	LP-2-7	Parking Area Lighting	X					Open 7 am - 10 pm M-F	
-02	LP-2-9	Parking Area Security Lighting		X					
-03	LP-2-11	Building "A" Security Lighting			X				
-04	LP-2-8	Building "B" Security Lighting				X			
-05	LP-2-10	Entrance/Exit Canopy Lighting					X	Dark at 20c	
-06		Other Building Loads							
-07		Other Building Loads							
-08		Other Building Loads							
-09		Other Building Loads							
-10	PP-2-14	Bollards - Main Entrance Walkway					X	Dark at 20c	
-11	PP-2-16	Bollards - Visitor Parking					X	Dark at 20c	
-12	PP-2-18	Bollards - Security Lighting	X					Dark at 10c	
-13									
-14									

SWITCH DESIGNATION	BUTTON# (IF MANY)	RELAYS CONTROLLED PANEL # RELAYS*	DESCRIPTION	SPECIAL F
01	1	R1, R2	Parking Lots	
01	2	R10, R11, R12	Walkways	
01	3	R3, R4, R5	Security & Canopy Lighting	
01	4	R1-5, R10-12	Exterior - All	

Equipment Schedule

Catalog No.	Qty	Description
HIN12R12SP	1	Smartwired Control lighting control panel interior, 12 relays
HTUB12	1	Tub enclosure for lighting control panel, up to 12 relays, 16"x16.5"x4.5"
HCVR12SL	1	Surface mounted cover for lighting control panel, up to 12 relays, 16.28"x16.7"x.75"
HCLK8SS	1	Network clock/programmer for Smartwired Control lighting control panel
HPSM115/277	1	Power supply for lighting control panel, 115/277 VAC, 50/60 Hz
HDLS4SS	1	Dataline Switch, quad, 4 individual buttons plus master, single-gang, includes plate
HPCP8SS	1	Photocontrol package for Smartwired lighting control panel, with HPSA photocell
HDLW4		Dataline wire, 18 AWG (7 strands x 26 AWG) using 2 independent twisted pair (specify feet)

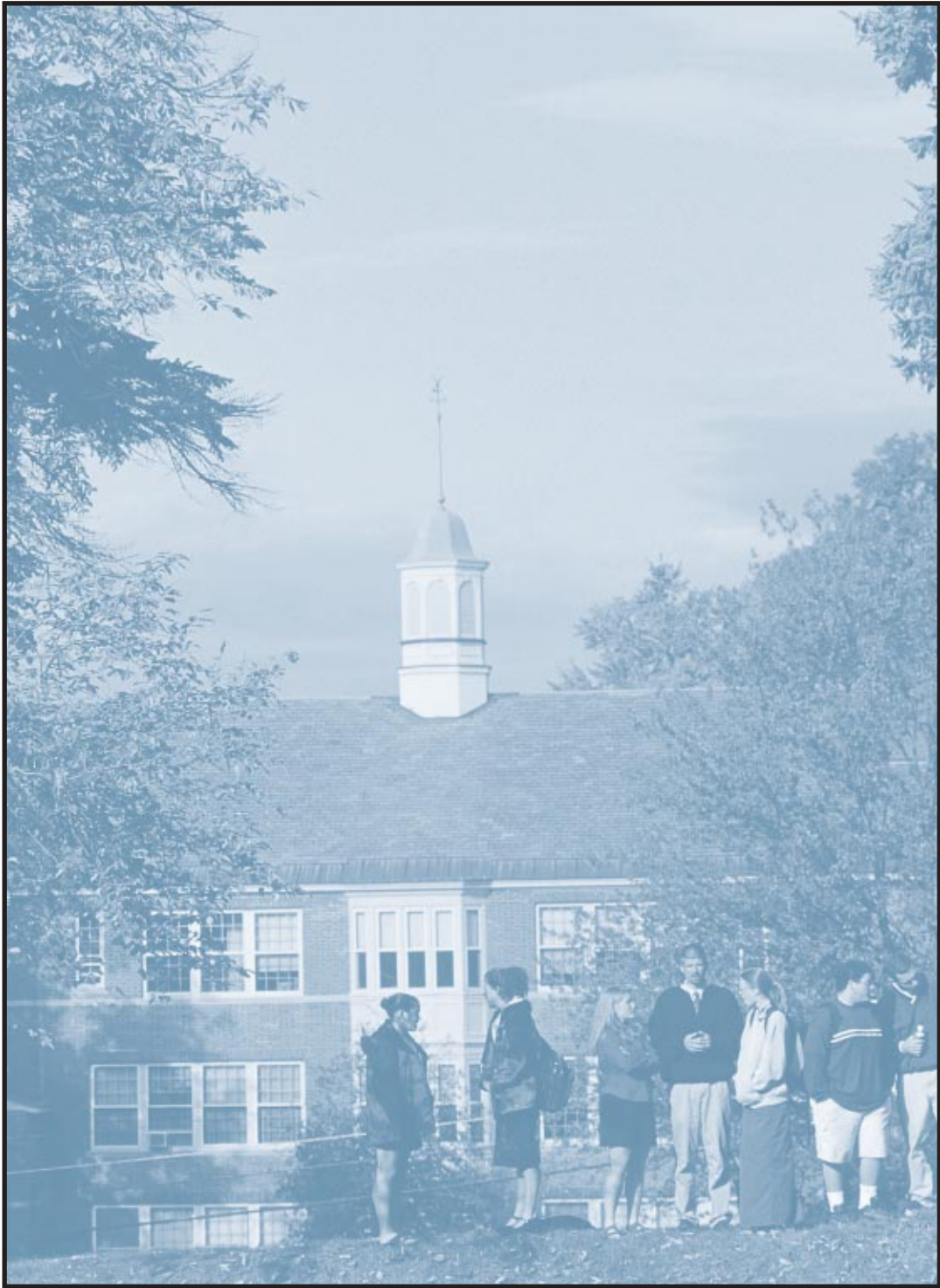

ASHRAE 90.1 - 2001 Energy Code

The ASHRAE 90.1-2001 Standard is available for purchase through ASHRAE. Visit www.ashrae.org to purchase the standard through its online bookstore. Lighting control highlights include:

Automatic Lighting Shut off*

- Buildings larger than 5000 sq ft must use an automatic control device to turn off lighting in all spaces. The automatic control device shall be either:
 - A programmable time scheduling device, where an independent program schedule shall be provided for areas less than or equal to 25,000 sq ft, but not more than one program schedule per floor, or
 - An occupancy sensor that turns lighting off within 30 minutes after the space is vacated, or
 - An unoccupied control signal from another control or alarm system

Space Control

- Each space that's enclosed by ceiling-height partitions must have at least one control device that independently controls the general lighting in the space. Each control device shall be activated either by an automatic motion sensor, or manually by an occupant.
 - For spaces equal to or less than 10,000 sq ft, each control device shall control a maximum of 2500 sq ft
 - For spaces greater than 10,000 sq ft, each control device shall control zones no larger than 10,000 sq ft
 - Each control device shall be capable of overriding the automatic lighting shut off for no more than four hours
 - Each control device shall be readily accessible and located so that the occupant can see lights from the controlling switch**

Exterior Lighting Control

- Lighting for all exterior applications not exempted in the Standard, shall be controlled by a photocell or astronomical time clock.

Tandem Wiring

- Luminaires that are in the same space and on the same control device, using one or three linear fluorescent lamps greater than 30 watts each, shall use two-lamp tandem-wired ballasts in place of single-lamp ballasts.

Energy code provisions vary from state to state. For more information, visit the Department of Energy website at www.energycodes.gov, which provides current information on the status of state energy codes as well as compliance and training tools.

*Lighting intended for 24 hour operation does not require an automatic control device.

**Remote location is permitted for reasons of safety or security.

Automatic Lighting Shut Off Compliance Guideline for ASHRAE 90.1 - 2001

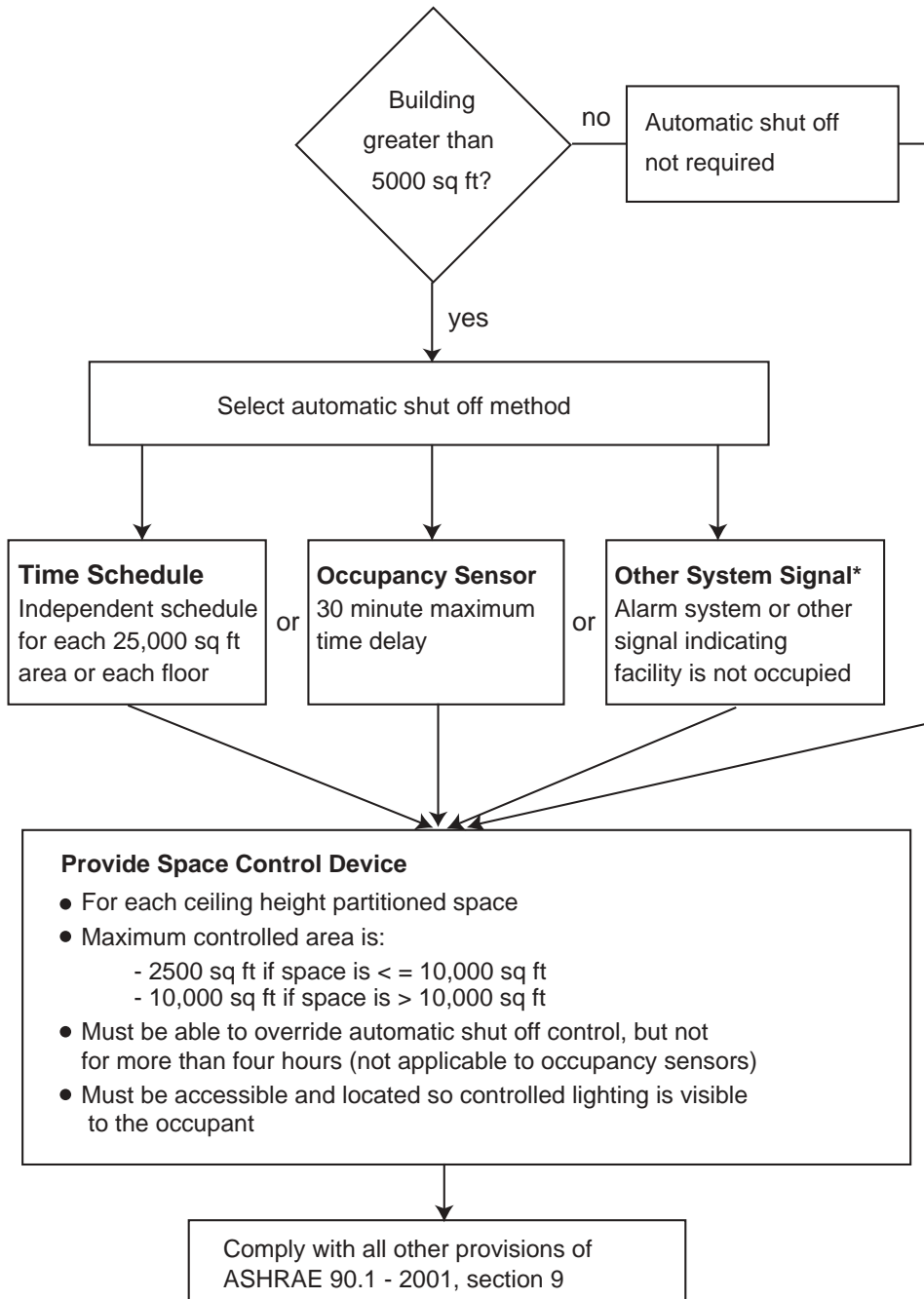

Lighting Control Best Practice Guide

S C H O O L S

Founded in 1984, The Watt Stopper is committed to developing efficient, energy saving lighting control solutions. Beginning with our first product line, occupancy sensors, we have continually worked to develop highly innovative, reliable products that offer a vast array of features.

Today, our product solutions include lighting control panels, daylighting controls, remote lighting controls, and integrated lighting and plug load controls. These versatile products offer ideal energy control solutions for every type of building.

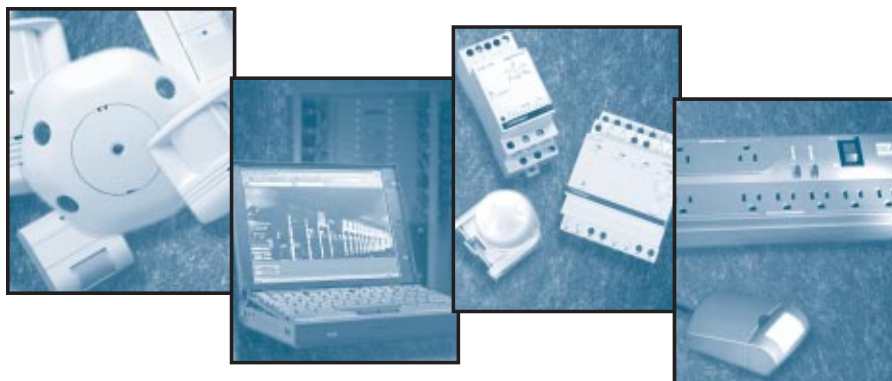

The Watt Stopper,® Inc.
2800 De La Cruz Blvd
Santa Clara, CA 95050

Tel: 800.879.8585
Fax: 408.988.5373

www.wattstopper.com

The Watt Stopper would like to acknowledge the help and assistance of the many specifiers and designers who provided input and feedback during the process of developing this document. A special thanks to:

Jim Westberg, U.S. DOE
Dr. Michael Kroelinger, Arizona State University
Ken Bauersnschub, Mark Greenawalt, P.E., and Dick Santistevan, P.E., Sullivan Designs
Ernie Pryor, RCDD, Orcutt/Winslow Partnership
The Architectural Design staff, Orcutt/Winslow Partnership
Paul Rossello, Ann Pacelli, David Verhegge, Excel Engineers
Don Happ, D.H. Lighting Solutions, Phoenix, AZ
Mark Ralston, Darrel Miller, P.E., LSW Engineers
Daniel Zuczek, Zuczek Lindstrom Lighting Associates
Naomi Miller, Naomi Miller Lighting Design
Michael Hall, Fanning/Howey Architects
Peter Egan, Light + Substance, Raleigh, NC